

Aqua Tanks™

 **STRATCO**





Aqua-Mod™ Tank

The innovative Stratco Aqua-Mod Tank is unmatched in quality and value for money. Designed especially for homes, units and townhouses where space is limited, its clean, smooth lines will create a seamless blend with your home's architecture. Available in un-painted galvanised or painted in your choice of a broad spectrum of colours, a Stratco Aqua-Mod will complement any outdoor environment.

With four sizes to choose from, there is an Aqua-Mod Tank for every requirement. The range includes a 500 litre One Module, a 1000 litre Two Module, an 870 litre Three Module, and a 2000 litre Four Module Tank. The One, Two and Four Module Tanks are supplied with a 3/4" outlet and tap, while the Three Module Tank has a 1/2" outlet and tap. All Aqua-Mods are supplied with an inbuilt filter, a 400mm x 400mm inspection point with a cover, and all inlets and outlets are protected with mosquito proof wire.

Optional extras include a different sized outlet and tap, a factory fitted flushing plug, and a tank stand tailored to your tank size. The stands are 500mm high, engineered for strength and made from galvanised steel. Optional adjustable feet kits are available with your stand to provide a stable footing on uneven ground.

Model	Capacity	Length	Width	Height
1 Module	500 litres	700mm	570mm	1420mm
2 Module	1000 litres	1400mm	570mm	1420mm
3 Module	870 litres	1760mm	570mm	1030mm
4 Module	2000 litres	2750mm	570mm	1420mm

Availability	Model	QLD	NSW	ACT	VIC	SA	WA	NT
	1 Module	-	-	-	•	-	-	-
	2 Module	•	•	•	•	•	•	-
	3 Module	•	•	•	•	•	•	-
	4 Module	•	•	•	•	•	•	-

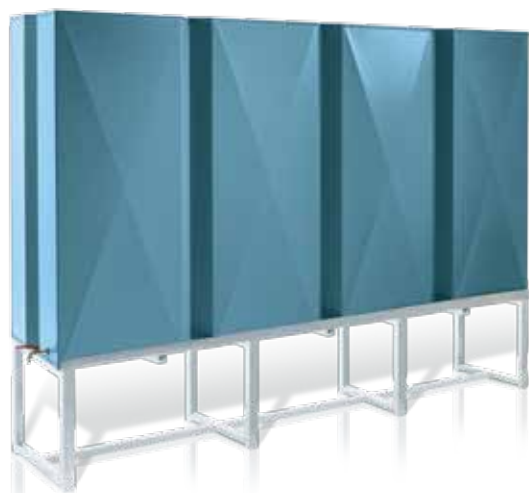



Aqua-Barrel® Tank

Form and function come together in the Aqua-Barrel Tank. It is a strong, modern tank with a slim design and stylish rounded curves. Designed to sit closely against an existing wall, the slim 560mm* width makes it ideal for installation under eaves and other narrow spaces. Available in a choice of colours, the Aqua-Barrel Tank will blend seamlessly with your outdoor environment.

The Aqua-Barrel Tank is manufactured from Aquaplate® steel to ensure your water tastes clean and fresh. The inside surface of Aquaplate steel is coated with a food grade polymer skin that provides clear, healthy rainwater, and has a very long, useable life.

The range has six sizes with five capacities to choose from depending on your State. The sizes are; a 500 litre, 1000 litre, 2000 litre, 3000 litre and a 5000 litre tank. The larger tanks have external bracing for added strength. All tanks are supplied with a 3/4" outlet and tap. A 300mm diameter mosquito proof inlet is fitted which doubles as an inspection point when removed.



Optional extras include a different sized outlet and a heavy-duty tank stand. The stands are 450mm high, engineered for strength and made from galvanised steel. The tank stands have rounded ends to match the tank. Adjustable feet kits are available with your stand to provide a stable footing on uneven ground.

Model	Capacity	Length	Width	Height
500 Low	500 litres	1400mm	560mm	810mm
1000 Low	1000 litres	2700mm	560mm*	810mm
1000	1000 litres	1400mm	560mm*	1550mm
2000	2000 litres	2700mm	560mm*	1550mm
3000	3000 litres	3000mm	760mm*	1550mm
5000	5000 litres	3420mm	1270mm*	1570mm

*50x50mm tubular steel external bracing used, which makes the actual total width of the tank an extra 100mm.

Availability	Model	QLD	NSW	ACT	VIC	SA	WA	NT
	500 Low	-	-	-	•	-	-	-
	1000 Low	-	-	-	•	-	•	-
	1000	-	-	-	•	•	•	-
	2000	-	•	•	•	•	•	-
	3000	•	-	-	•	-	-	-
	5000	•	-	-	-	-	-	-





Benefit from environmentally friendly cost savings.



Aqua-Quad™ Tank

New forms offer a fresh outlook on a traditional design in the Aqua-Quad Tank. Aqua-Quad Tanks provide the style of a round corrugated design, yet maximise their water holding capacity and the floor space they occupy through their square form. The Stratco Aqua-Quad Tank will fit neatly into corners and against walls, making it the perfect solution in situations where space is limited.

Aqua-Classic™ Tank

Embodying the traditional character of a round corrugated tank, the Aqua-Classic Tank has a timeless style that complements both traditional and modern homes. The round form of the Aqua-Classic Tank is not only attractive, but also very strong. The Aqua-Classic Tank is available in a 3000 litre or a 5000 litre size.

Aqua-Quad and Aqua-Classic Tanks are manufactured from Aquaplate® steel. The inside surface of Aquaplate steel is coated with a food grade polymer skin that provides clear, healthy rainwater, and has a long, useable life. The bottom of the tank features a second layer of Aquaplate steel with the polymer side facing outwards to protect the base of the tank from the elements.

Aqua-Quad and Aqua-Classic Tanks are supplied with a 1" outlet and tap and have an inbuilt 300mm diameter filter that doubles as an inspection point when removed. They can be placed on a suitable concrete slab, with the best results achieved when bitumen saturated felt is laid between the tank and base. Other options include a different sized outlet and tap.

Model	Capacity	Length	Width	Height
Aqua-Quad	2000 litres	1360mm	1360mm	1550mm
Aqua-Classic	3000 litres	-	1530mm	2030mm
Aqua-Classic	5000 litres	-	1950mm	2030mm

Availability	Model	QLD	NSW	ACT	VIC	SA	WA	NT
	Aqua-Quad: 2000 litres	•	•	•	•	•	•	-
	Aqua-Classic: 3000 litres	•	•	•	•	•	•	-
	5000 litres	•	•	•	•	•	•	-





Aqua-Link™ Tank

Smooth, rounded curves are a feature of the Stratco Aqua-Link™ system; the next generation of modular rainwater tanks. The modern, stylish 1100 litre modules can be linked together to provide maximum water catchment where space is limited.

The strong modules are only 800mm wide, 1900mm long and 1340mm high, making Aqua-Link Tanks easy to manoeuvre, even into difficult locations. Each module has a convex end and a concave end. The concave end is designed to accommodate another module, or an optional overflow moulding that can be included to complete the rounded curves of the tank.

Manufactured from food grade polyethylene that is protected against ultraviolet rays. The tank is formed in one piece from rotomoulded plastic that forms a thick wall. It will not corrode and has excellent impact resistance. This advanced manufacturing method delivers one of the strongest, cleanest and most durable tanks available. Stratco Aqua-Link Tanks are designed, engineered and tested to meet all relevant Australian Standards.

Aqua-Link Tanks come standard with a moulded brass outlet, 300mm mosquito proof inlet that also acts as a leaf strainer and inspection point, and an integrated overflow outlet.



Component	Capacity	Length	Width	Height
Tank	1100 litres	1900mm	800mm	1340mm
Optional Overflow	N/A	350mm	800mm	1340mm

Availability	QLD	NSW	ACT	VIC	SA	WA	NT
	-	•	-	•	•	-	-



Hydrate your home and budget by harvesting rainwater.

Aqua-Line™ Tank

Modern and contemporary style is embodied in the extremely durable and practical Stratco Aqua-Line Tank. Manufactured from food grade polyethylene they feature a clean, smooth surface with thin, attractive strengthening ribs. With their combination of style and appealing colours, Aqua-Line Tanks are designed to be an attractive addition to your home.

Manufactured in one piece from rotomoulded plastic, Aqua-Line Tanks use this advanced manufacturing method to deliver one of the strongest, cleanest and most durable tanks available. The polyethylene used is protected against ultraviolet rays and forms a thick wall that has excellent impact resistance and will not corrode. The tank is maintenance free and easy to move and relocate. Aqua-Line Tanks are engineered and tested to meet all relevant Australian Standards.



Two sizes are available; a 3000 and 5000 litre round design. Brass outlets are moulded into the tank at the time of manufacture for a watertight seal. The outlets are available in either 1" or 2" diameters and can be located in one of four locations around the tank. The tanks come standard with a 300mm inlet that also acts as a leaf strainer and inspection point. An optional 400mm inlet with light guard is also available. The 90mm overflow can be positioned on either side of the tank. All the fittings are protected with mosquito proof mesh.

Model	Capacity	Width	Height
3000L Squat	3000 litres	1860mm	1780mm
3000L	3000 litres	1500mm	2250mm
5000L Squat	5000 litres	2060mm	2000mm
5000L	5000 litres	1860mm	2380mm

Availability	Model	QLD	NSW	ACT	VIC	SA	WA	NT
	3000L Squat	-	-	-	-	•	-	-
	3000L	•	-	-	-	-	-	-
	5000L Squat	-	-	-	-	•	-	-
	5000L	•	-	-	-	-	-	-





Harvesting Rainwater

Rainwater is a valuable natural resource that can be collected as an environmentally responsible way to provide real cost savings to any home or business. Homeowners and urban planning authorities are recognising the benefits of rainwater collection with new legislation being introduced in many areas.

A rainwater tank can save up to 100,000 litres of water a year in an average home. Collected rainwater can be used to water the garden, wash the car, or as drinking water. With additional plumbing and a pump, a tank can be used to flush the toilet, fill a washing machine, fill a water heater or be used through a cold water tap.

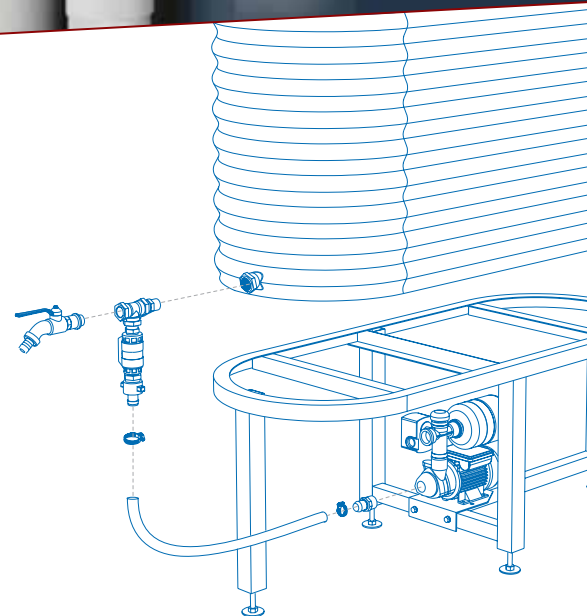

Pumps and Accessories

Get the full potential out of your rainwater tank with a complete range of pumps and accessories from Stratco. A wide range of pumps are available. The pump you choose will depend on the tank size, the requirements of the appliance that will feed from the tank, the diameter of the plumbing pipes and the pressure required.

If you choose to run your appliances solely from tank water, you may need a top-up facility to fill part of the tank with mains water when the rainwater gets low. When connecting to mains water, a backflow prevention device is needed to prevent the reverse flow of polluted water from contaminating drinking water. Some pumps have backflow and top-up devices built into their design. Stratco can supply separate top-up devices, backflow prevention devices and any pipes and fittings needed to complete the system.

Talk to Stratco when making a decision about what tank, pumps and accessories are required for the application. When installing a rainwater tank, never attempt to install a tank to mains water without a qualified plumber.

Maintenance

When installing your tank, ensure it is on a level, solid base. Do not store the tank on its side. Flush the tank before use, this is very important when connecting a pump. Do not stand on the top of the tank as the lid is not designed to support weight. When attaching the tap, use thread tape on the tap fitting and do not over tighten it. While the inlet filter provided with your tank will stop sticks and leaf debris entering the tank, it is also important to ensure the runoff area to the tank is free of debris. Clean the gutters every two months, or more regularly if trees overhang the roof. Remove any sludge from inside the tank when necessary. Do not scrub or scratch the interior surface of the tank because it has a protective coating covering the walls. Stratco tanks are produced from the highest quality materials and will provide many years of service if the important recommendations set out in the Stratco 'Selection, Use and Maintenance' brochure are followed.



CONTACT

1300 165 165



ZY-BRO-RT

© Copyright April 08

All brands and logos/images accompanied by ® or ™ are trade marks of Stratco (Australia) Pty Limited.

www.stratco.com.au