

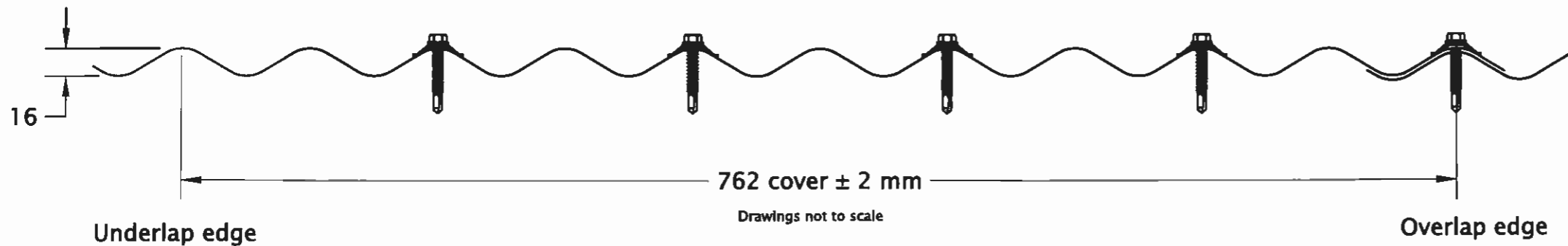

CGI ROOF CLADDING PERFORMANCE IN CYCLONIC REGION C

0.42mm and 0.48mm BMT ASI397/G550 AZ150



Maximum Allowable Spans (mm) for Region C

Terrain Category	KI	5m Building Height						10m Building Height							
		Pz (kPa)	0.42mm BMT			0.48mm BMT			Pz (kPa)	0.42mm BMT			0.48mm BMT		
			Single	End	Internal	Single	End	Internal		Single	End	Internal	Single	End	Internal
1 & 2	1	4.16	800	950	1150	900	1200	1270	4.61	800	950	1080	900	1120	1190
	1.5	5.33	800	920	980	900	1000	1080	5.91	800	850	910	900	920	990
	2	6.50	780	780	840	840	840	910	7.20	700	700	770	740	740	820
2.5	1	3.53	800	950	1200	900	1300	1400	4.12	800	950	1150	900	1210	1280
	1.5	4.52	800	950	1090	900	1140	1210	5.28	800	930	990	900	1010	1090
	2	5.52	800	900	960	900	980	1050	6.43	780	780	850	840	840	920
3 & 4	1	2.95	800	950	1200	900	1300	1530	3.65	800	950	1200	900	1300	1370
	1.5	3.78	800	950	1200	900	1280	1340	4.68	800	950	1070	900	1110	1180
	2	4.61	800	950	1080	900	1120	1190	5.71	800	870	940	900	950	1020

NOTE: The values are for use with steel supports with a minimum thickness of 0.75mm BMT G550.

Fastener Details in Region C

Steel	0.75 - 4.0mm	Minimum 13 gauge x 50mm hex head screw with cyclonic washer assembly
Timber	Hardwood (F11)	Minimum 13 gauge x 50mm hex head screw with cyclonic washer assembly
	Softwood (F5)	Minimum 13 gauge x 50mm hex head screw with cyclonic washer assembly

Fixing Recommendations:

CGI sheets should be laid into the prevailing wind and slit neatly on the preceding roof sheet, with a side lap of 1.5 corrugations. They should be fixed within the recommended support spacings. Avoid 'stretching' the width of the sheet when installing, as this could allow wind and rain to enter. Side lap fixing is recommended to maintain a weather proof seal and to secure the overlap especially when the roof is walked on occasionally. This is best done with either 8 x 12mm self drilling stitching screws or a 3.2mm blind rivet (rivets should be sealed to prevent water penetration). It is recommended side lap fasteners are secured mid-span, when roofing spans exceed 900mm. At the end of the sheets, the valleys of each corrugation should be turned up at the ridge of the roof using a turn up tool.

Walking on CGI

When walking on CGI roofing, it is recommended you walk over the purlins to avoid any damage. Wear flat, rubber soled shoes and walk flat footed, spreading your weight over as many corrugations as possible. For carport and verandah applications, crawl boards should be used to avoid damage during installation and maintenance.

Maintenance Requirements:

The performance of CGI over time depends on its correct application and maintenance. Maintenance should be performed as often as is required to remove any dirt, salt and pollutants. Where CGI is used in severely corrosive environments, cleaning should be performed more often. It is important that screws have the same life expectancy as the CGI cladding you have specified. Packs of CGI should always be kept dry and stored above ground level on site. If the sheets have become wet, they should be separated, wiped and placed in the open to dry. Refer to the Stratco "Selection, Use and Maintenance" Brochure, for more detailed information about the correct use and maintenance of this product.

Design Pressures Pz - Ult. Limit State (kPa)

Span (mm)	0.42mm BMT			0.48mm BMT		
	Single	End	Internal	Single	End	Internal
700	7.21	7.21	7.88	7.60	7.60	8.31
1000	4.80	4.80	5.25	5.39	5.39	5.89
1300	2.96	2.96	3.24	3.69	3.69	4.04
1600	1.69	1.69	1.85	2.50	2.50	2.73
1900	1.00	1.00	1.09	1.82	1.82	1.99

Carport / Verandah Spans in Region C

Terrain Category	Base Metal Thickness	
	0.42mm BMT	0.48mm BMT
1 & 2	1190	1330
2.5	1290	1440
3 & 4	1390	1570

NOTE: The values are for use with steel supports with a minimum thickness of 0.75mm BMT G550.

JULY 2009

Design Criteria

The following criteria was used in the development of the tables:

1. Region C with a design return period of 500 yrs.
2. $V_r = F_c 66m/s$ (limit state), with $F_c = 1.05$
3. $M_s/M_t/M_d = 1.00$

Height (m)	Terrain/height Multiplier (M_z, cat)		
	1&2	2.5	3&4
≤ 5	0.95	0.88	0.80
≤ 10	1.0	0.95	0.89

Pressure coefficients:

Internal $C_{pi} = +0.7$

External $C_{pe} = -0.9$

Carport and Verandah Spans

The carport and verandah spans only apply to structures not enclosed by peripheral walls. Spans are based on height $\leq 5m$, $C_{pn} = -0.9$ and $KI = 1.5$ applied over the entire span, and are suitable for all span types. Loads on supporting purlins may limit these spans.

Stratco can provide additional engineering advice if any design parameters vary from those above.

Limitations

1. Design pressures and maximum allowable spans are based on five fasteners per sheet per support.
2. When fixing over insulation, screw length should be increased to ensure sufficient penetration of the fastener.
3. Maximum allowable overhang is 200mm for roof cladding.

Notes

1. Cyclonic Testing in accordance with Building Code of Australia (BCA) - Low-High-Low Pressure Testing.
2. Design Criteria are determined in accordance with AS/NZS1170.2 2002 Wind Actions.

CGI ROOF CLADDING PERFORMANCE IN CYCLONIC REGION D

0.42mm and 0.48mm BMT AS1397/G550 AZ150

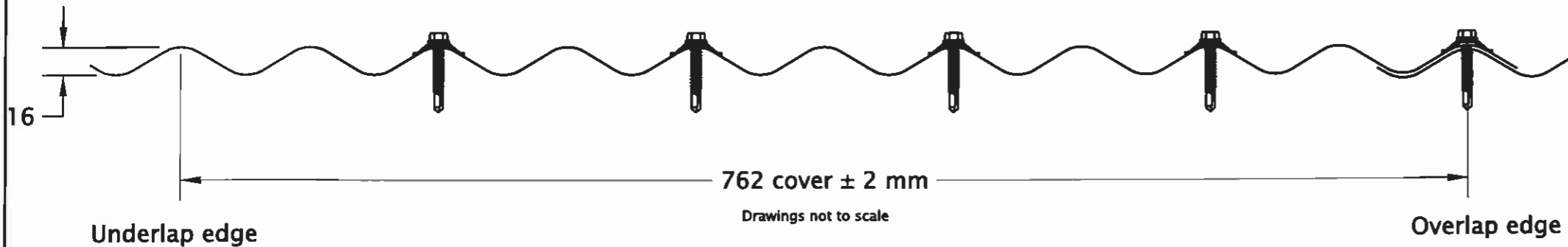

Maximum Allowable Spans (mm) for Region D

Terrain Category	KI	5m Building Height						10m Building Height							
		P _z (kPa)	0.42mm BMT			0.48mm BMT			P _z (kPa)	0.42mm BMT			0.48mm BMT		
			Single	End	Internal	Single	End	Internal		Single	End	Internal	Single	End	Internal
1 & 2	1	6.71	750	750	820	810	810	890	7.43	670	670	740	710	710	800
	1.5	8.60	580	580	640	610	610	670	9.53	520	520	570	550	550	610
	2	10.48	480	480	520	500	500	550	11.62	430	430	470	450	450	500
2.5	1	5.69	800	880	940	900	950	1020	6.64	760	760	830	820	820	870
	1.5	7.29	690	690	750	720	720	810	8.51	590	590	640	620	620	680
	2	8.89	560	560	620	590	590	650	10.37	480	480	530	510	510	560
3 & 4	1	4.76	800	950	1060	900	1100	1170	5.89	800	850	920	900	920	980
	1.5	6.10	800	820	890	890	890	970	7.54	660	660	730	700	700	770
	2	7.43	670	670	740	710	710	800	9.20	540	540	590	570	570	630

NOTE: The values are for use with steel supports with a minimum thickness of 0.75mm BMT G550.

Fastener Details in Region D

Steel	0.75 - 4.0mm	Minimum 13 gauge x 50mm hex head screw with cyclonic washer assembly
Timber	Hardwood (F11)	Minimum 13 gauge x 50mm hex head screw with cyclonic washer assembly
	Softwood (F5)	Minimum 13 gauge x 50mm hex head screw with cyclonic washer assembly

Fixing Recommendations:

CGI sheets should be laid into the prevailing wind and sit neatly on the preceding roof sheet, with a side lap of 1.5 corrugations. They should be fixed within the recommended support spacings. Avoid 'stretching' the width of the sheet when installing, as this could allow wind and rain to enter. Side lap fixing is recommended to maintain a weather proof seal and to secure the overlap especially when the roof is walked on occasionally. This is best done with either 8 x 12mm self drilling stitching screws or a 3.2mm blind rivet (rivets should be sealed to prevent water penetration). It is recommended side lap fasteners are secured mid-span, when roofing spans exceed 900mm. At the end of the sheets, the valleys of each corrugation should be turned up at the ridge of the roof using a turn up tool.

Walking on CGI

When walking on CGI roofing, it is recommended you walk over the purlins to avoid any damage. Wear flat, rubber soled shoes and walk flat footed, spreading your weight over as many corrugations as possible. For carport and verandah applications, crawl boards should be used to avoid damage during installation and maintenance.

Maintenance Requirements:

The performance of CGI over time depends on its correct application and maintenance. Maintenance should be performed as often as is required to remove any dirt, salt and pollutants. Where CGI is used in severely corrosive environments, cleaning should be performed more often. It is important that screws have the same life expectancy as the CGI cladding you have specified. Packs of CGI should always be kept dry and stored above ground level on site. If the sheets have become wet, they should be separated, wiped and placed in the open to dry. Refer to the Stratco "Selection, Use and Maintenance" Brochure, for more detailed information about the correct use and maintenance of this product.

Design Pressures P_z - Ult. Limit State (kPa)

Span (mm)	0.42mm BMT			0.48mm BMT		
	Single	End	Internal	Single	End	Internal
700	7.21	7.21	7.88	7.60	7.60	8.31
1000	4.80	4.80	5.25	5.39	5.39	5.89
1300	2.96	2.96	3.24	3.69	3.69	4.04
1600	1.69	1.69	1.85	2.50	2.50	2.73
1900	1.00	1.00	1.09	1.82	1.82	1.99

Carport / Verandah Spans in Region D

Terrain Category	Base Metal Thickness	
	0.42mm BMT	0.48mm BMT
1 & 2	880	950
2.5	990	1090
3 & 4	1110	1230

NOTE: The values are for use with steel supports with a minimum thickness of 0.75mm BMT G550.

JULY 2009

Design Criteria

The following criteria was used in the development of the tables:

1. Region D with a design return period of 500 yrs.
2. V_r = F_d 80m/s (limit state), with F_d = 1.1
3. M_s/M_t/M_d = 1.00

Height (m)	Terrain/height Multiplier (M _z ,cat)		
	1&2	2.5	3&4
≤5	0.95	0.88	0.80
≤10	1.0	0.95	0.89

Pressure coefficients:

Internal C_{pi} = +0.7
External C_{pe} = -0.9

Carport and Verandah Spans

The carport and verandah spans only apply to structures not enclosed by peripheral walls. Spans are based on height ≤5m, C_{pn} = -0.9 and KI = 1.5 applied over the entire span, and are suitable for all span types. Loads on supporting purlins may limit these spans.

Stratco can provide additional engineering advice if any design parameters vary from those above.

Limitations

1. Design pressures and maximum allowable spans are based on five fasteners per sheet per support.
2. When fixing over insulation, screw length should be increased to ensure sufficient penetration of the fastener.
3. Maximum allowable overhang is 200mm for roof cladding.

Notes

1. Cyclonic Testing in accordance with Building Code of Australia (BCA) - Low-High-Low Pressure Testing.
2. Design Criteria are determined in accordance with AS/NZS1170.2 2002 Wind Actions.



PRODEK® ROOF CLADDING PERFORMANCE IN CYCLONIC REGION C

0.42mm and 0.48mm BMT AS1397/G550 AZ150

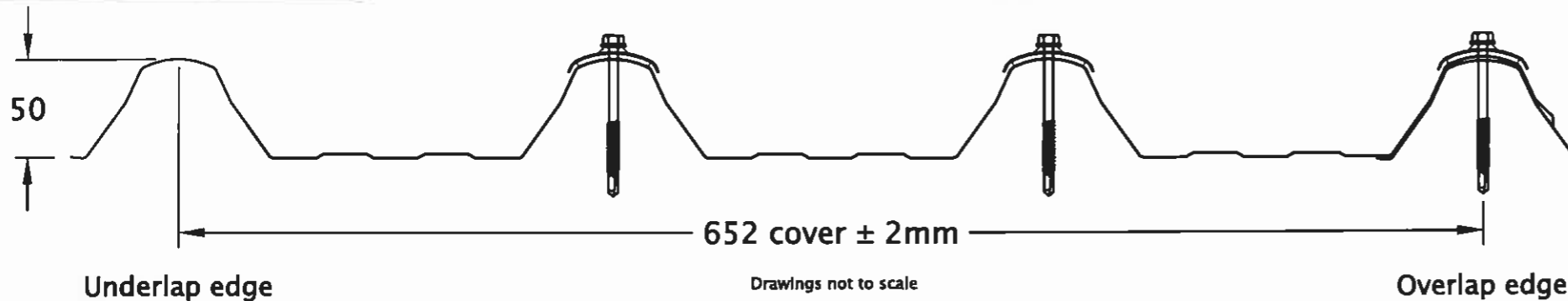

Maximum Allowable Spans (mm) for Region C

Terrain Category	KI	5m Building Height						10m Building Height							
		Pz (kPa)	0.42mm BMT			0.48mm BMT			Pz (kPa)	0.42mm BMT			0.48mm BMT		
			Single	End	Internal	Single	End	Internal		Single	End	Internal	Single	End	Internal
1 & 2	1	4.16	1460	1460	1550	1620	1620	1720	4.61	1370	1370	1450	1510	1510	1610
	1.5	5.33	1220	1220	1310	1350	1350	1450	5.91	1110	1110	1210	1240	1240	1340
	2	6.50	1010	1010	1110	1120	1120	1230	7.20	910	910	990	1000	1000	1110
2.5	1	3.53	1620	1620	1700	1790	1790	1890	4.12	1470	1470	1560	1640	1640	1730
	1.5	4.52	1380	1380	1470	1540	1540	1630	5.28	1230	1230	1320	1370	1370	1470
	2	5.52	1180	1180	1280	1320	1320	1420	6.43	1020	1020	1120	1140	1140	1240
3 & 4	1	2.95	1780	1780	1860	1980	1980	2070	3.65	1590	1590	1670	1760	1760	1850
	1.5	3.78	1550	1550	1640	1720	1720	1820	4.68	1350	1350	1440	1500	1500	1590
	2	4.61	1370	1370	1450	1510	1510	1610	5.71	1150	1150	1240	1280	1280	1380

Design Pressures Pz - Ult. Limit State (kPa)

Span (mm)	0.42mm BMT			0.48mm BMT		
	Single	End	Internal	Single	End	Internal
1000	6.58	6.58	7.20	7.22	7.22	7.90
1300	4.95	4.95	5.41	5.62	5.62	6.14
1600	3.62	3.62	3.95	4.28	4.28	4.68
1900	2.58	2.58	2.82	3.20	3.20	3.50
2200	1.84	1.84	2.01	2.39	2.39	2.61
2500	1.40	1.40	1.53	1.84	1.84	2.01
2700	1.27	1.27	1.39	1.62	1.62	1.77

Fastener Details in Region C

Steel	1.5 - 4.0mm	Minimum 13 gauge x 75mm hex head screw with cyclonic washer assembly
Timber	Hardwood (F11)	Minimum 13 gauge hex head screw embedded at least 35mm into timber
	Softwood (F5)	Minimum 13 gauge hex head screw embedded at least 35mm into timber

Fixing Recommendations:

Prodek sheets should be laid into the prevailing wind and sit neatly on the preceding roof sheet. They should be fixed within the recommended support spacings. Avoid 'stretching' the width of the sheet when installing, as this could allow wind and rain to enter. Flashings turn downs into the pan of Prodek should always be notched around the rib for maximum weather tightness. For spans between 1200mm and 3600mm, side lap fasteners are recommended for use at mid-span. For spans beyond 3600mm use two evenly spaced fasteners between supports to secure the side lap. Use either 8 x 12mm self drilling stitching screws or a 4.8mm blind rivet (rivets should be sealed to prevent water penetration). On roofing, at the end of the sheets, turn the pans up at the roof ridge and down into the gutter using a turn up/down tool.

Walking on Prodek

When walking on Prodek roofing, it is recommended you walk over the purlins to avoid any damage. Wear flat, rubber soled shoes and walk flat footed in the sheet pans only. For carport and verandah applications, crawl boards should be used to avoid damage during installation and maintenance.

Maintenance Requirements:

The performance of Prodek over time depends on its correct application and maintenance. Maintenance should be performed as often as is required to remove any dirt, salt and pollutants. Where Prodek is used in severely corrosive environments, cleaning should be performed more often. It is important that screws have the same life expectancy as the Prodek cladding you have specified. Packs of Prodek should always be kept dry and stored above ground level on site. If the sheets have become wet, they should be separated, wiped and placed in the open to dry. Refer to the Stratco "Selection, Use and Maintenance" Brochure, for more detailed information about the correct use and maintenance of this product.

Carport / Verandah Spans in Region C

Terrain Category	Base Metal Thickness	
	0.42mm BMT	0.48mm BMT
1 & 2	1620	1800
2.5	1770	1970
3 & 4	1930	2150

JULY 2009

Design Criteria

The following criteria was used in the development of the tables:

1. Region C with a design return period of 500 yrs.
2. $V_r = F_d$ 66m/s (limit state), with $F_d = 1.05$
3. $M_s/M_t/M_d = 1.00$

Height (m)	Terrain/height Multiplier (M_z, cat)		
	1&2	2.5	3&4
≤ 5	0.95	0.88	0.80
≤ 10	1.0	0.95	0.89

Pressure coefficients:

Internal $C_{pi} = +0.7$
External $C_{pe} = -0.9$

Carport and Verandah Spans

The carport and verandah spans only apply to structures not enclosed by peripheral walls. Spans are based on height $\leq 5m$, $C_{pn} = -0.9$ and $KI = 1.5$ applied over the entire span, and are suitable for all span types. Loads on supporting purlins may limit these spans.

Stratco can provide additional engineering advice if any design parameters vary from those above.

Limitations

1. Design pressures and maximum allowable spans are based on five fasteners per sheet per support.
2. When fixing over insulation, screw length should be increased to ensure sufficient penetration of the fastener.
3. Maximum allowable overhang is 200mm for roof cladding.

Notes

1. Cyclonic Testing in accordance with Building Code of Australia (BCA) - Low-High-Low Pressure Testing.
2. Design Criteria are determined in accordance with AS/NZS1170.2 2002 Wind Actions.

PRODEK® ROOF CLADDING PERFORMANCE IN CYCLONIC REGION D

0.42mm and 0.48mm BMT AS1397/G550 AZ150

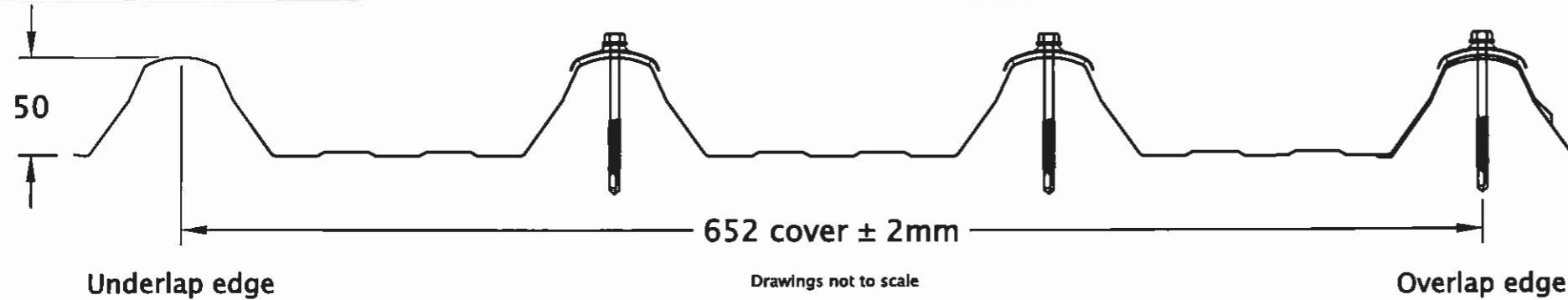

Maximum Allowable Spans (mm) for Region D

Terrain Category	KI	5m Building Height						10m Building Height							
		P _z (kPa)	0.42mm BMT			0.48mm BMT			P _z (kPa)	0.42mm BMT			0.48mm BMT		
			Single	End	Internal	Single	End	Internal		Single	End	Internal	Single	End	Internal
1 & 2	1	6.71	980	980	1070	1090	1090	1190	7.43	880	880	960	970	970	1070
	1.5	8.60	760	760	830	830	830	910	9.53	690	690	750	750	750	820
	2	10.48	620	620	680	680	680	750	11.62	560	560	610	620	620	670
2.5	1	5.69	1150	1150	1240	1280	1280	1380	6.64	990	990	1080	1100	1100	1200
	1.5	7.29	900	900	980	990	990	1090	8.51	770	770	840	840	840	920
	2	8.89	730	730	800	810	810	880	10.37	630	630	690	690	690	760
3 & 4	1	4.76	1330	1330	1420	1480	1480	1580	5.89	1120	1120	1210	1240	1240	1340
	1.5	6.10	1080	1080	1170	1200	1200	1300	7.54	870	870	950	950	950	1050
	2	7.43	880	880	960	970	970	1070	9.20	710	710	780	780	780	850

Fastener Details in Region D

Steel	1.5 - 4.0mm	Minimum 13 gauge x 75mm hex head screw with cyclonic washer assembly
Timber	Hardwood (F11)	Minimum 13 gauge hex head screw embedded at least 35mm into timber
	Softwood (F5)	Minimum 13 gauge hex head screw embedded at least 35mm into timber

Fixing Recommendations:

Prodek sheets should be laid into the prevailing wind and sit neatly on the preceding roof sheet. They should be fixed within the recommended support spacings. Avoid 'stretching' the width of the sheet when installing, as this could allow wind and rain to enter. Flashings turn downs into the pan of Prodek should always be notched around the rib for maximum weather tightness. For spans between 1200mm and 3600mm, side lap fasteners are recommended for use at mid-span. For spans beyond 3600mm use two evenly spaced fasteners between supports to secure the side lap. Use either 8 x 12mm self drilling stitching screws or a 4.8mm blind rivet (rivets should be sealed to prevent water penetration). On roofing, at the end of the sheets, turn the pans up at the roof ridge and down into the gutter using a turn up/down tool.

Walking on Prodek

When walking on Prodek roofing, it is recommended you walk over the purlins to avoid any damage. Wear flat, rubber soled shoes and walk flat footed in the sheet pans only. For carport and verandah applications, crawl boards should be used to avoid damage during installation and maintenance.

Maintenance Requirements:

The performance of Prodek over time depends on its correct application and maintenance. Maintenance should be performed as often as is required to remove any dirt, salt and pollutants. Where Prodek is used in severely corrosive environments, cleaning should be performed more often. It is important that screws have the same life expectancy as the Prodek cladding you have specified. Packs of Prodek should always be kept dry and stored above ground level on site. If the sheets have become wet, they should be separated, wiped and placed in the open to dry. Refer to the Stratco "Selection, Use and Maintenance" Brochure, for more detailed information about the correct use and maintenance of this product.

Design Pressures P_z - Ult. Limit State (kPa)

Span (mm)	0.42mm BMT			0.48mm BMT		
	Single	End	Internal	Single	End	Internal
1000	6.58	6.58	7.20	7.22	7.22	7.90
1300	4.95	4.95	5.41	5.62	5.62	6.14
1600	3.62	3.62	3.95	4.28	4.28	4.68
1900	2.58	2.58	2.82	3.20	3.20	3.50
2200	1.84	1.84	2.01	2.39	2.39	2.61
2500	1.40	1.40	1.53	1.84	1.84	2.01
2700	1.27	1.27	1.39	1.62	1.62	1.77

Carport / Verandah Spans in Region D

Terrain Category	Base Metal Thickness	
	0.42mm BMT	0.48mm BMT
1 & 2	1160	1290
2.5	1300	1470
3 & 4	1500	1660

JULY 2009

Design Criteria

The following criteria was used in the development of the tables:

1. Region D with a design return period of 500 yrs.
2. V_r = F_d 80m/s (limit state), with F_d = 1.1
3. M_s/M_t/M_d = 1.00

Height (m)	Terrain/height Multiplier (M _{z,cat})		
	1&2	2.5	3&4
≤5	0.95	0.88	0.80
≤10	1.0	0.95	0.89

Pressure coefficients:

Internal C_{pi} = +0.7

External C_{pe} = -0.9

Carport and Verandah Spans

The carport and verandah spans only apply to structures not enclosed by peripheral walls. Spans are based on height ≤5m, C_{pn} = -0.9 and KI = 1.5 applied over the entire span, and are suitable for all span types. Loads on supporting purlins may limit these spans.

Stratco can provide additional engineering advice if any design parameters vary from those above.

Limitations

1. Design pressures and maximum allowable spans are based on five fasteners per sheet per support.
2. When fixing over insulation, screw length should be increased to ensure sufficient penetration of the fastener.
3. Maximum allowable overhang is 200mm for roof cladding.

Notes

1. Cyclonic Testing in accordance with Building Code of Australia (BCA) - Low-High-Low Pressure Testing.
2. Design Criteria are determined in accordance with AS/NZS1170.2 2002 Wind Actions.



SMARTSPAN® ROOF CLADDING PERFORMANCE IN CYCLONIC REGION C

0.42mm and 0.48mm BMT ASI397/G550 AZ150

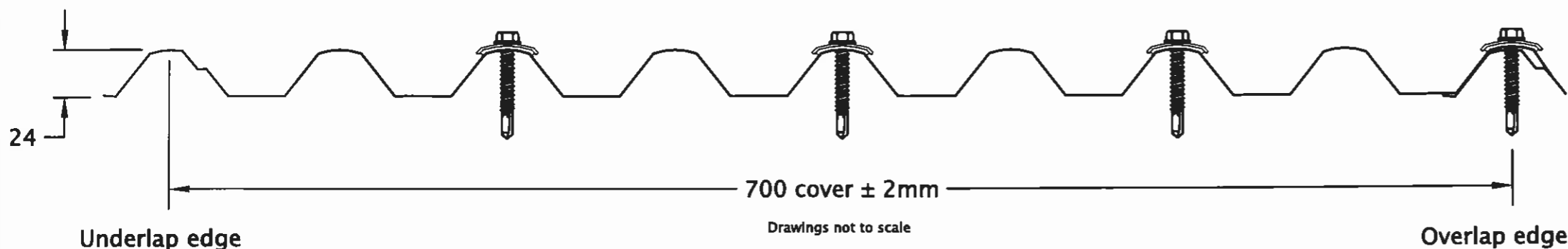

Maximum Allowable Spans (mm) for Region C

Terrain Category	KI	5m Building Height						10m Building Height							
		Pz (kPa)	0.42mm BMT			0.48mm BMT			Pz (kPa)	0.42mm BMT			0.48mm BMT		
			Single	End	Internal	Single	End	Internal		Single	End	Internal	Single	End	Internal
1 & 2	1	4.16	1350	1500	1590	1610	1610	1700	4.61	1350	1390	1480	1500	1500	1590
	1.5	5.33	1240	1240	1330	1350	1350	1440	5.91	1120	1120	1220	1240	1240	1340
	2	6.50	1020	1020	1120	1130	1130	1230	7.20	910	910	1000	1020	1020	1120
2.5	1	3.53	1350	1660	1750	1770	1770	1860	4.12	1350	1510	1600	1620	1620	1710
	1.5	4.52	1350	1410	1500	1520	1520	1610	5.28	1250	1250	1340	1360	1360	1450
	2	5.52	1200	1200	1300	1310	1310	1410	6.43	1030	1030	1130	1150	1150	1240
3 & 4	1	2.95	1350	1800	1930	1960	1960	2050	3.65	1350	1630	1720	1740	1740	1830
	1.5	3.78	1350	1590	1680	1700	1700	1790	4.68	1350	1380	1470	1490	1490	1580
	2	4.61	1350	1390	1480	1500	1500	1590	5.71	1160	1160	1260	1280	1280	1370

Design Pressures Pz - Ult. Limit State (kPa)

Span (mm)	0.42mm BMT			0.48mm BMT		
	Single	End	Internal	Single	End	Internal
1000	6.62	6.62	7.24	7.35	7.35	8.04
1300	5.05	5.05	5.53	5.61	5.61	6.13
1600	3.78	3.78	4.13	4.20	4.20	4.60
1900	2.79	2.79	3.05	3.13	3.13	3.42
2200	2.09	2.09	2.29	2.39	2.39	2.61
2500	1.68	1.68	1.84	1.99	1.99	2.17
2700	1.57	1.57	1.72	1.90	1.90	2.08

Fastener Details in Region C

Steel	1.5 - 4.0mm	Minimum 13 gauge x 50mm hex head screw with cyclonic washer assembly
Timber	Hardwood (F11)	Minimum 13 gauge hex head screw embedded at least 35mm into timber
	Softwood (F5)	Minimum 13 gauge hex head screw embedded at least 35mm into timber

Fixing Recommendations:

Smartspan sheets should be laid into the prevailing wind and sit neatly on the preceding roof sheet. They should be fixed within the recommended support spacings. Avoid 'stretching' the width of the sheet when installing, as this could allow wind and rain to enter. If the spans exceed 900mm, it is recommended that side lap fasteners are used at mid-span. Side lap fixing will help maintain a weather proof seal and will secure the overlap especially when the roof is walked on occasionally. This is best done with either 8 x 12mm self drilling screws or a 3.2mm blind rivet (rivets should be sealed to prevent water penetration). On roofing, at the end of the sheets, turn the pans up at the roof ridge and down into the gutter using a turn up/down tool.

Walking on Smartspan

When walking on Smartspan roofing, it is recommended you walk over the purlins to avoid any damage. Wear flat, rubber soled shoes and walk flat footed, spreading your weight over as many crests as possible. For carport and verandah applications, crawl boards should be used to avoid damage during installation and maintenance.

Maintenance Requirements:

The performance of Smartspan over time depends on its correct application and maintenance. Maintenance should be performed as often as is required to remove any dirt, salt and pollutants. Where Smartspan is used in severely corrosive environments, cleaning should be performed more often. It is important that screws have the same life expectancy as the Smartspan cladding you have specified. Packs of Smartspan should always be kept dry and stored above ground level on site. If the sheets have become wet, they should be separated, wiped and placed in the open to dry. Refer to the Stratco "Selection, Use and Maintenance" Brochure, for more detailed information about the correct use and maintenance of this product.

Carport / Verandah Spans in Region C

Terrain Category	Base Metal Thickness	
	0.42mm BMT	0.48mm BMT
1 & 2	1670	1780
2.5	1830	1950
3 & 4	2000	2150

JULY 2009

Design Criteria

The following criteria was used in the development of the tables:

1. Region C with a design return period of 500 yrs.
2. $V_r = F_d$ 66m/s (limit state), with $F_d = 1.05$
3. $M_s/M_t/M_d = 1.00$

Height (m)	Terrain/height Multiplier (M_z, cat)		
	1&2	2.5	3&4
≤ 5	0.95	0.88	0.80
≤ 10	1.0	0.95	0.89

Pressure coefficients:

Internal $C_{pi} = +0.7$

External $C_{pe} = -0.9$

Carport and Verandah Spans

The carport and verandah spans only apply to structures not enclosed by peripheral walls. Spans are based on height $\leq 5m$, $C_{pn} = -0.9$ and $KI = 1.5$ applied over the entire span, and are suitable for all span types. Loads on supporting purlins may limit these spans.

Stratco can provide additional engineering advice if any design parameters vary from those above.

Limitations

1. Design pressures and maximum allowable spans are based on five fasteners per sheet per support.
2. When fixing over insulation, screw length should be increased to ensure sufficient penetration of the fastener.
3. Maximum allowable overhang is 200mm for roof cladding.

Notes

1. Cyclonic Testing In accordance with Building Code of Australia (BCA) - Low-High-Low Pressure Testing.
2. Design Criteria are determined in accordance with AS/NZS1170.2 2002 Wind Actions.

SMARTSPAN® ROOF CLADDING PERFORMANCE IN CYCLONIC REGION D

0.42mm and 0.48mm BMT AS1397/G550 AZ150

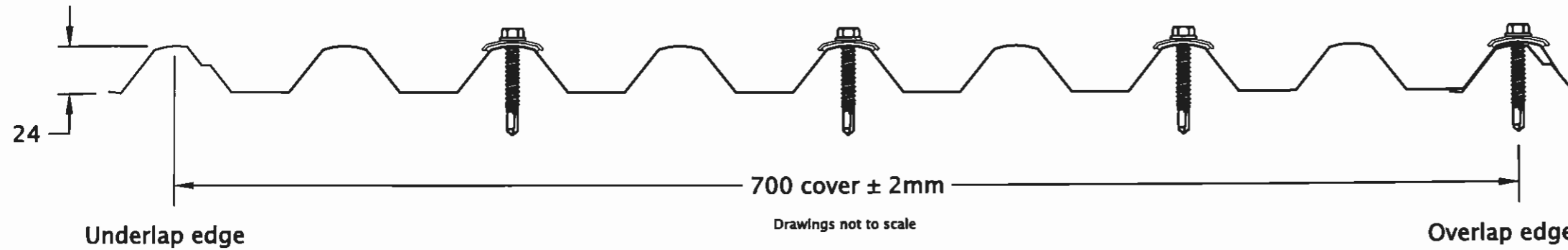

Maximum Allowable Spans (mm) for Region D

Terrain Category	KI	5m Building Height						10m Building Height							
		Pz (kPa)	0.42mm BMT			0.48mm BMT			Pz (kPa)	0.42mm BMT			0.48mm BMT		
			Single	End	Internal	Single	End	Internal		Single	End	Internal	Single	End	Internal
1 & 2	1	6.71	980	980	1080	1100	1100	1200	7.43	890	890	970	980	980	1080
	1.5	8.60	770	770	840	850	850	930	9.53	690	690	760	770	770	840
	2	10.48	630	630	690	700	700	760	11.62	560	560	620	630	630	690
2.5	1	5.69	1170	1170	1260	1280	1280	1370	6.64	990	990	1090	1110	1110	1210
	1.5	7.29	900	900	990	1000	1000	1110	8.51	770	770	850	860	860	940
	2	8.89	740	740	810	820	820	900	10.37	630	630	690	700	700	770
3 & 4	1	4.76	1350	1360	1450	1470	1470	1560	5.89	1130	1130	1230	1240	1240	1340
	1.5	6.10	1090	1090	1190	1210	1210	1300	7.54	870	870	950	970	970	1070
	2	7.43	890	890	970	980	980	1080	9.20	710	710	780	790	790	870

Design Pressures Pz - Ult. Limit State (kPa)

Span (mm)	0.42mm BMT			0.48mm BMT		
	Single	End	Internal	Single	End	Internal
1000	6.62	6.62	7.24	7.35	7.35	8.04
1300	5.05	5.05	5.53	5.61	5.61	6.13
1600	3.78	3.78	4.13	4.20	4.20	4.60
1900	2.79	2.79	3.05	3.13	3.13	3.42
2200	2.09	2.09	2.29	2.39	2.39	2.61
2500	1.68	1.68	1.84	1.99	1.99	2.17
2700	1.57	1.57	1.72	1.90	1.90	2.08

Fastener Details in Region D

Steel	1.5 - 4.0mm	Minimum 13 gauge x 50mm hex head screw with cyclonic washer assembly
Timber	Hardwood (F11)	Minimum 13 gauge hex head screw embedded at least 35mm into timber
	Softwood (F5)	Minimum 13 gauge hex head screw embedded at least 35mm into timber

Fixing Recommendations:

Smartspan sheets should be laid into the prevailing wind and sit neatly on the preceding roof sheet. They should be fixed within the recommended support spacings. Avoid 'stretching' the width of the sheet when installing, as this could allow wind and rain to enter. If the spans exceed 900mm, it is recommended that side lap fasteners are used at mid-span. Side lap fixing will help maintain a weather proof seal and will secure the overlap especially when the roof is walked on occasionally. This is best done either 8 x 12mm self drilling stitching screws or a 3.2mm blind rivet (rivets should be sealed to prevent water penetration). On roofing, at the end of the sheets, turn the pans up at the roof ridge and down into the gutter using a turn up/down tool.

Walking on Smartspan

When walking on Smartspan roofing, it is recommended you walk over the purlins to avoid any damage. Wear flat, rubber soled shoes and walk flat footed, spreading your weight over as many crests as possible. For carport and verandah applications, crawl boards should be used to avoid damage during installation and maintenance.

Maintenance Requirements:

The performance of Smartspan over time depends on its correct application and maintenance. Maintenance should be performed as often as is required to remove any dirt, salt and pollutants. Where Smartspan is used in severely corrosive environments, cleaning should be performed more often. It is important that screws have the same life expectancy as the Smartspan cladding you have specified. Packs of Smartspan should always be kept dry and stored above ground level on site. If the sheets have become wet, they should be separated, wiped and placed in the open to dry. Refer to the Stratco "Selection, Use and Maintenance" Brochure, for more detailed information about the correct use and maintenance of this product.

Carport / Verandah Spans in Region D

Terrain Category	Base Metal Thickness	
	0.42mm BMT	0.48mm BMT
1 & 2	1170	1290
2.5	1350	1460
3 & 4	1530	1640

JULY 2009

Design Criteria

The following criteria was used in the development of the tables:

1. Region D with a design return period of 500 yrs.
2. $V_r = F_d$ 80m/s (limit state), with $F_d = 1.1$
3. $M_s/M_t/M_d = 1.00$

Height (m)	Terrain/height Multiplier (M_z, cat)		
	1&2	2.5	3&4
≤ 5	0.95	0.88	0.80
≤ 10	1.0	0.95	0.89

Pressure coefficients:

Internal $C_{pi} = +0.7$

External $C_{pe} = -0.9$

Carport and Verandah Spans

The carport and verandah spans only apply to structures not enclosed by peripheral walls. Spans are based on height $\leq 5m$, $C_{pn} = -0.9$ and $KI = 1.5$ applied over the entire span, and are suitable for all span types. Loads on supporting purlins may limit these spans.

Stratco can provide additional engineering advice if any design parameters vary from those above.

Limitations

1. Design pressures and maximum allowable spans are based on five fasteners per sheet per support.
2. When fixing over insulation, screw length should be increased to ensure sufficient penetration of the fastener.
3. Maximum allowable overhang is 200mm for roof cladding.

Notes

1. Cyclonic Testing in accordance with Building Code of Australia (BCA) - Low-High-Low Pressure Testing.
2. Design Criteria are determined in accordance with AS/NZS1170.2 2002 Wind Actions.



SUPERDEK® ROOF CLADDING PERFORMANCE IN CYCLONIC REGION C

0.42mm and 0.48mm BMT AS1397/G550 AZ150

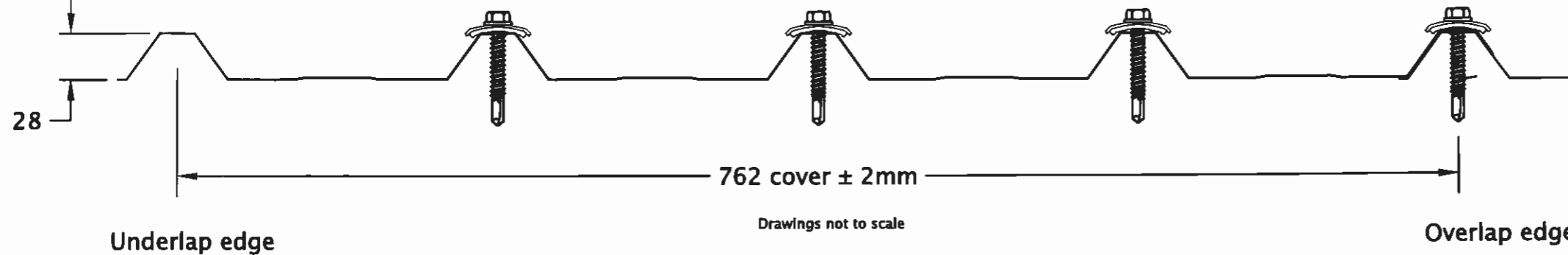

Maximum Allowable Spans (mm) for Region C

Terrain Category	KI	5m Building Height						10m Building Height							
		Pz (kPa)	0.42mm BMT			0.48mm BMT			Pz (kPa)	0.42mm BMT			0.48mm BMT		
			Single	End	Internal	Single	End	Internal		Single	End	Internal	Single	End	Internal
1 & 2	1	4.16	1010	1010	1070	1100	1100	1150	4.61	950	950	1010	1030	1030	1090
	1.5	5.33	850	850	910	940	940	1000	5.91	770	770	840	870	870	930
	2	6.50	700	700	760	800	800	870	7.20	630	630	690	730	730	790
2.5	1	3.53	1120	1120	1170	1190	1190	1250	4.12	1020	1020	1080	1100	1100	1160
	1.5	4.52	960	960	1020	1050	1050	1100	5.28	850	850	920	950	950	1010
	2	5.52	820	820	880	920	920	980	6.43	700	700	770	810	810	870
3 & 4	1	2.95	1150	1220	1270	1290	1290	1340	3.65	1100	1100	1150	1180	1180	1230
	1.5	3.78	1080	1080	1130	1160	1160	1210	4.68	940	940	1000	1020	1020	1080
	2	4.61	950	950	1010	1030	1030	1090	5.71	800	800	860	890	890	950

NOTE: The values are for use with steel supports with a minimum thickness of 0.75mm BMT G550.

Fastener Details in Region C

Steel	0.75 - 4.0mm	Minimum 13 gauge x 50mm hex head screw with cyclonic washer assembly
Timber	Hardwood (F11)	Minimum 13 gauge hex head screw embedded at least 35mm into timber
	Softwood (F5)	Minimum 13 gauge hex head screw embedded at least 35mm into timber

Fixing Recommendations:

Superdek sheets should be laid into the prevailing wind. They should be fixed within the recommended support spacings. Avoid 'stretching' the width of the sheet when installing, as this could allow wind and rain to enter. Due to its higher rib height, flashing turn downs into the pan of Superdek should always be notched around the rib to provide maximum weather tightness. When spans exceed 900mm it is recommended that side laps are fixed at midspan to ensure a weatherproof seal and to secure the overlap, especially when the roof is walked on occasionally. Use either 8 x 12mm self drill stitching screws or 3.2mm sealed blind rivets. At the ends of the sheets, the pans should be turned up at the ridge of the roof and down into the gutter using a turn up/down tool.

Walking on Superdek

When walking on Superdek roofing, it is recommended you walk over the purlins to avoid any damage. Wear flat, rubber soled shoes and walk flat footed in the sheet pans only. For carport and verandah applications, crawl boards should be used to avoid damage during installation and maintenance.

Maintenance Requirements:

The performance of Superdek over time depends on its correct application and maintenance. Maintenance should be performed as often as is required to remove any dirt, salt and pollutants. Where Superdek is used in severely corrosive environments, cleaning should be performed more often. It is important that screws have the same life expectancy as the Superdek cladding you have specified. Packs of Superdek should always be kept dry and stored above ground level on site. If the sheets have become wet, they should be separated, wiped and placed in the open to dry. Refer to the Stratco "Selection, Use and Maintenance" Brochure, for more detailed information about the correct use and maintenance of this product.

Design Pressures Pz - Ult. Limit State (kPa)

Span (mm)	0.42mm BMT			0.48mm BMT		
	Single	End	Internal	Single	End	Internal
700	6.51	6.51	7.12	7.50	7.50	8.20
1000	4.29	4.29	4.69	4.90	4.90	5.36
1300	2.60	2.60	2.84	2.95	2.95	3.23
1600	1.44	1.44	1.58	1.64	1.64	1.80
1900	0.82	0.82	0.90	0.98	0.98	1.07
2100	0.70	0.70	0.77	0.90	0.90	0.98

Carport / Verandah Spans in Region C

Terrain Category	Base Metal Thickness	
	0.42mm BMT	0.48mm BMT
1 & 2	1120	1200
2.5	1220	1290
3 & 4	1320	1390

NOTE: The values are for use with steel supports with a minimum thickness of 0.75mm BMT G550.

JULY 2009

Design Criteria

The following criteria was used in the development of the tables:

1. Region C with a design return period of 500 yrs.
2. $V_r = F_c$ 66m/s (limit state), with $F_c = 1.05$
3. $M_s/M_t/M_d = 1.00$

Height (m)	Terrain/height Multiplier (M_z, cat)		
	1&2	2.5	3&4
≤ 5	0.95	0.88	0.80
≤ 10	1.0	0.95	0.89

Pressure coefficients:

Internal $C_{pi} = +0.7$

External $C_{pe} = -0.9$

Carport and Verandah Spans

The carport and verandah spans only apply to structures not enclosed by peripheral walls. Spans are based on height $\leq 5m$, $C_{pn} = -0.9$ and $KI = 1.5$ applied over the entire span, and are suitable for all span types. Loads on supporting purlins may limit these spans.

Stratco can provide additional engineering advice if any design parameters vary from those above.

Limitations

1. Design pressures and maximum allowable spans are based on five fasteners per sheet per support.
2. When fixing over insulation, screw length should be increased to ensure sufficient penetration of the fastener.
3. Maximum allowable overhang is 200mm for roof cladding.

Notes

1. Cyclonic Testing in accordance with Building Code of Australia (BCA) - Low-High-Low Pressure Testing.
2. Design Criteria are determined in accordance with AS/NZS1170.2 2002 Wind Actions.



SUPERDEK® ROOF CLADDING PERFORMANCE IN CYCLONIC REGION D

0.42mm and 0.48mm BMT AS1397/G550 AZ150

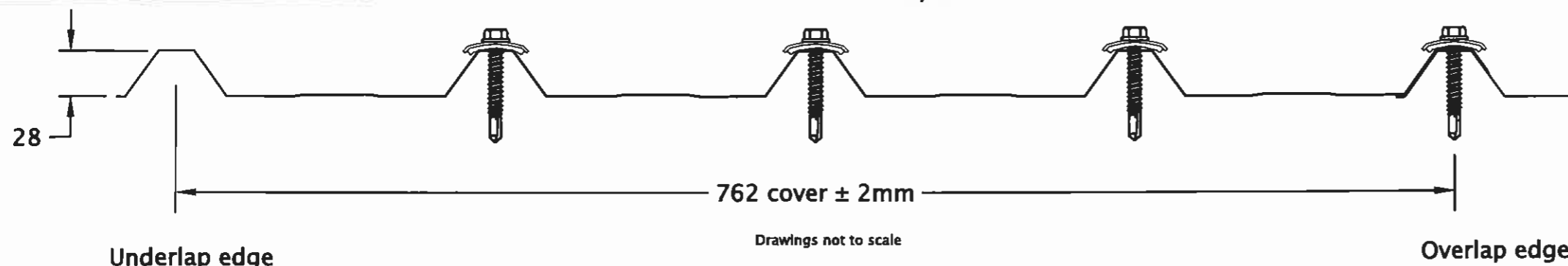

Maximum Allowable Spans (mm) for Region D

Terrain Category	KI	5m Building Height						10m Building Height							
		P _z (kPa)	0.42mm BMT			0.48mm BMT			P _z (kPa)	0.42mm BMT			0.48mm BMT		
			Single	End	Internal	Single	End	Internal		Single	End	Internal	Single	End	Internal
1 & 2	1	6.71	670	670	740	780	780	840	7.43	610	610	670	700	700	770
	1.5	8.60	530	530	570	610	610	660	9.53	470	470	520	550	550	600
	2	10.48	430	430	470	500	500	540	11.62	390	390	420	450	450	490
2.5	1	5.69	800	800	860	900	900	960	6.64	680	680	750	790	790	850
	1.5	7.29	620	620	680	720	720	780	8.51	530	530	580	610	610	670
	2	8.89	510	510	560	590	590	640	10.37	430	430	480	500	500	550
3 & 4	1	4.76	930	930	990	1010	1010	1070	5.89	770	770	840	870	870	930
	1.5	6.10	750	750	810	850	850	910	7.54	600	600	660	690	690	760
	2	7.43	610	610	670	700	700	770	9.20	490	490	540	570	570	620

NOTE: The values are for use with steel supports with a minimum thickness of 0.75mm BMT G550.

Fastener Details in Region D

Steel	0.75 - 4.0mm	Minimum 13 gauge x 50mm hex head screw with cyclonic washer assembly
Timber	Hardwood (F11)	Minimum 13 gauge hex head screw embedded at least 35mm into timber
	Softwood (F5)	Minimum 13 gauge hex head screw embedded at least 35mm into timber

Fixing Recommendations:

Superdek sheets should be laid into the prevailing wind. They should be fixed within the recommended support spacings. Avoid 'stretching' the width of the sheet when installing, as this could allow wind and rain to enter. Due to its higher rib height, flashing turn downs into the pan of Superdek should always be notched around the rib to provide maximum weather tightness. When spans exceed 900mm it is recommended that side laps are fixed at midspan to ensure a weatherproof seal and to secure the overlap, especially when the roof is walked on occasionally. Use either 8 x 12mm self drill stitching screws or 3.2mm sealed blind rivets. At the ends of the sheets, the pans should be turned up at the ridge of the roof and down into the gutter using a turn up/down tool.

Walking on Superdek

When walking on Superdek roofing, it is recommended you walk over the purlins to avoid any damage. Wear flat, rubber soled shoes and walk flat footed in the sheet pans only. For carport and verandah applications, crawl boards should be used to avoid damage during installation and maintenance.

Maintenance Requirements:

The performance of Superdek over time depends on its correct application and maintenance. Maintenance should be performed as often as is required to remove any dirt, salt and pollutants. Where Superdek is used in severely corrosive environments, cleaning should be performed more often. It is important that screws have the same life expectancy as the Superdek cladding you have specified. Packs of Superdek should always be kept dry and stored above ground level on site. If the sheets have become wet, they should be separated, wiped and placed in the open to dry. Refer to the Stratco "Selection, Use and Maintenance" Brochure, for more detailed information about the correct use and maintenance of this product.

Design Pressures P_z - Ult. Limit State (kPa)

Span (mm)	0.42mm BMT			0.48mm BMT		
	Single	End	Internal	Single	End	Internal
700	6.51	6.51	7.12	7.50	7.50	8.20
1000	4.29	4.29	4.69	4.90	4.90	5.36
1300	2.60	2.60	2.84	2.95	2.95	3.23
1600	1.44	1.44	1.58	1.64	1.64	1.80
1900	0.82	0.82	0.90	0.98	0.98	1.07
2100	0.70	0.70	0.77	0.90	0.90	0.98

Carport / Verandah Spans in Region D

Terrain Category	Base Metal Thickness	
	0.42mm BMT	0.48mm BMT
1 & 2	800	900
2.5	920	1010
3 & 4	1040	1120

NOTE: The values are for use with steel supports with a minimum thickness of 0.75mm BMT G550.

JULY 2009

Design Criteria

The following criteria was used in the development of the tables:

1. Region D with a design return period of 500 yrs.
2. V_r = F_d 80m/s (limit state), with F_d = 1.1
3. M_s/M_t/M_d = 1.00

Height (m)	Terrain/height Multiplier (M _{z,cat})		
	1&2	2.5	3&4
≤5	0.95	0.88	0.80
≤10	1.0	0.95	0.89

Pressure coefficients:

Internal C_{pl} = +0.7

External C_{pl} = -0.9

Carport and Verandah Spans

The carport and verandah spans only apply to structures not enclosed by peripheral walls. Spans are based on height ≤5m, C_{pn} = -0.9 and KI = 1.5 applied over the entire span, and are suitable for all span types. Loads on supporting purlins may limit these spans.

Stratco can provide additional engineering advice if any design parameters vary from those above.

Limitations

1. Design pressures and maximum allowable spans are based on five fasteners per sheet support.
2. When fixing over insulation, screw length should be increased to ensure sufficient penetration of the fastener.
3. Maximum allowable overhang is 200mm for roof cladding.

Notes

1. Cyclonic Testing in accordance with Building Code of Australia (BCA) - Low-High-Low Pressure Testing.
2. Design Criteria are determined in accordance with AS/NZS1170.2 2002 Wind Actions.