

INTRODUCING THE CLICKFAST® FASCIA AND GUTTER SYSTEM



The Clickfast Fascia and Gutter System was originally designed by Stratco and has proven to be the most successful fascia and gutter system in Australia using a flat steel fascia.

It has been used successfully by major builders for more than 20 years and remains the industry leader. It is one of the

few products in Australia to receive the coveted "classic" design award. In addition to design excellence, this also guarantees a friendly, tried and usable system for the installer.

HOW TO USE THIS MANUAL

Before attempting to install the Clickfast Fascia and Gutter system to a new home, you should read the Clickfast Fascia and Gutter brochure and also this installation manual completely. If further advice is required, contact your nearest Stratco sales office.

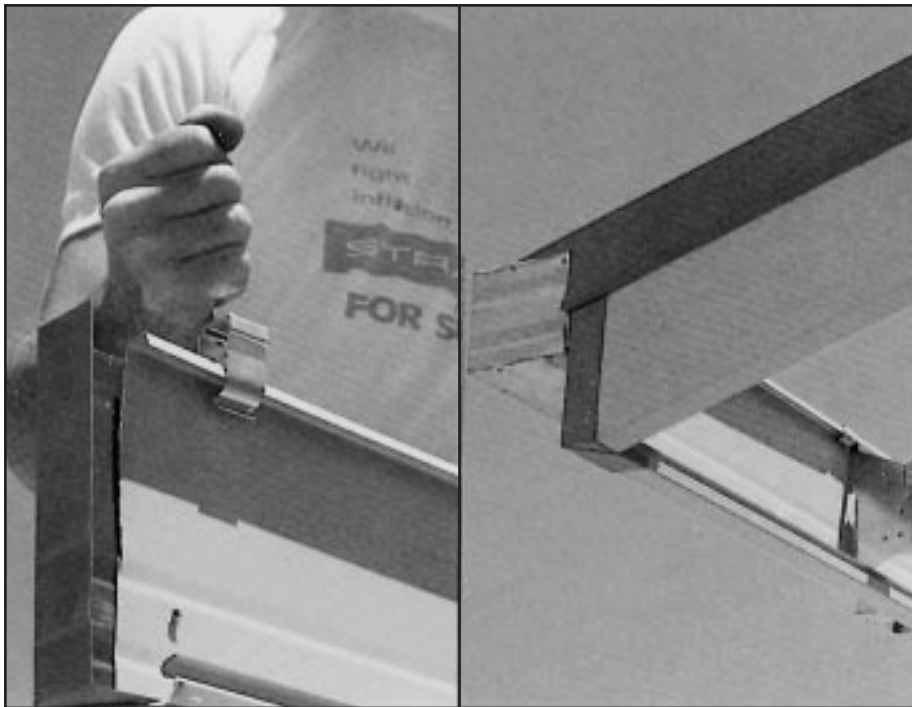

COMPONENTS OF THE CLICKFAST® FASCIA AND GUTTER SYSTEM

1: 185MM FLAT FASCIA

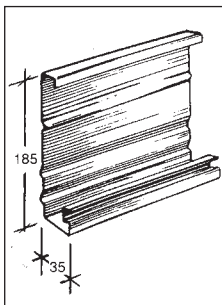

2: STANDARD RAFTER BRACKET

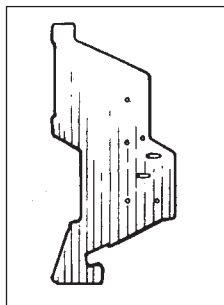

3: HIP RAFTER BRACKET

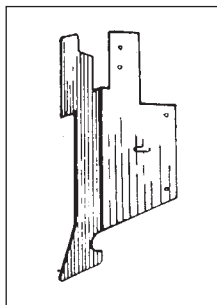

4: EXTERNAL MITRE

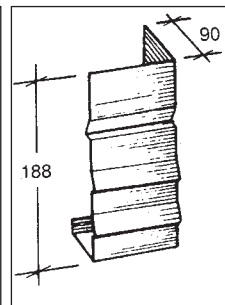

5: INTERNAL MITRE

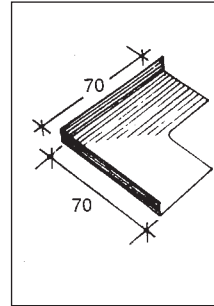

6: JOINING SLEEVE

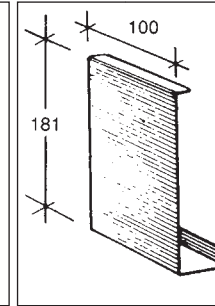

7: BARGE RAFTER BRACKET

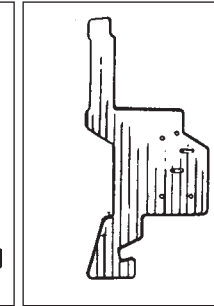

8: SUSPENSION CLIP

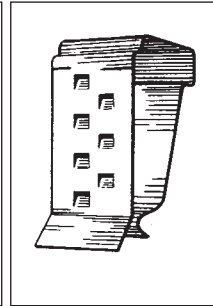

9: BARGE APEX COVER

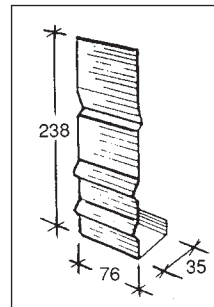

10: BARGE MOULD

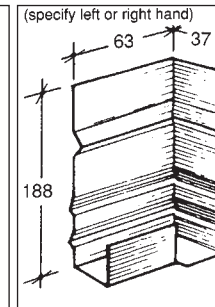

11: BARGE GUTTER

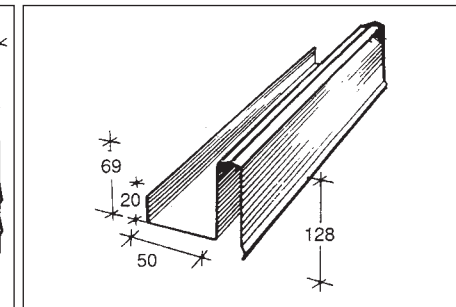

1 185MM FLAT FASCIA

This fascia is a non structural component designed to cover the end of rafters, provide support for the gutter and is suitable to support a 4.5mm or 6mm soffit lining placed horizontally, or a 4.5mm soffit raked up to 15°.

2 STANDARD RAFTER BRACKET

This bracket supports the fascia and is nailed to the side of each rafter.

3 HIP RAFTER BRACKET

This bracket is bent at 45° and is used on hip rafters to provide a strong external corner.

4 EXTERNAL MITRE

These are fitted on the outside of the fascia for all 90° external corners. The ribs in the mitre continue the smooth line of the fascia around external corners.

5 INTERNAL MITRE

After the fascia has been formed around an internal corner, this component is simply riveted to the underside of the fascia.

6 JOINING SLEEVE

This component is fixed internally, joining two longer lengths of fascia together. It provides the ideal method of joining two lengths.

7 BARGE RAFTER BRACKET

This is used to support the fascia when it is being used as a barge. The top of the bracket is recessed to allow the barge gutter to sit neatly.

8 SUSPENSION CLIPS

These clips are a specially designed clip made of spring steel and are placed at approximately 1.2 metre intervals along the fascia. It allows an adequate fall to be given to the gutter.

9 BARGE APEX COVER

This cover enables the apex of two joining barges to be joined neatly.

10 BARGE MOULD (specify left or right hand)

These are used to provide a neat corner where the fascia and barge meets. The ribs on the barge mould allow a smooth flowing line to run along the fascia and continue neatly up the barge. They must be ordered as left or right hand. The long face of the barge mould runs along the fascia.

11 BARGE GUTTER

This specially manufactured gutter fits over the top of the barge and is supported by timber outriggers. It allows the small amount of water which falls between the last tile and the fascia to run to the gutter.

EAVES & VERGE CONSTRUCTION

TILE ROOFS

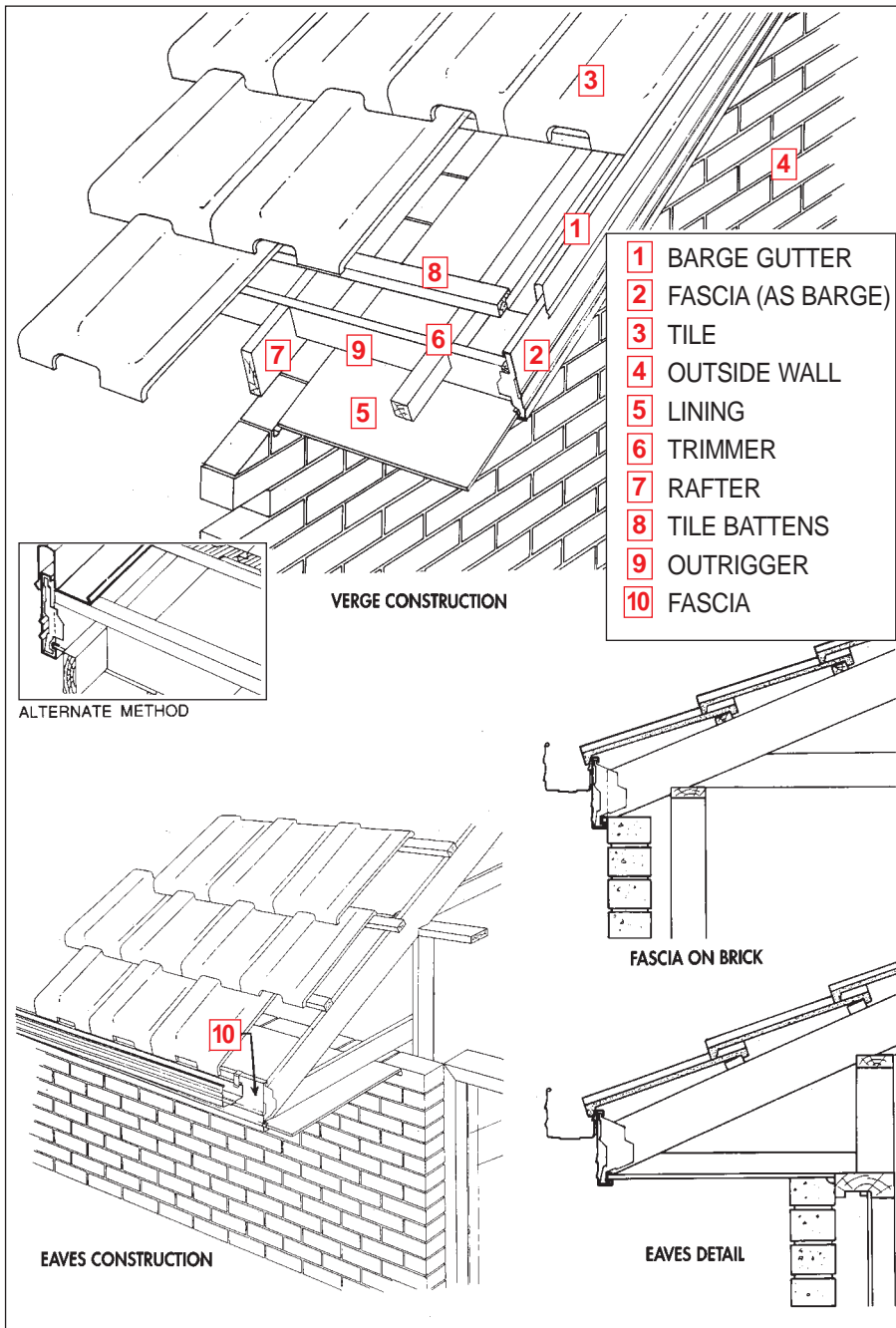

SHEETMETAL ROOFS

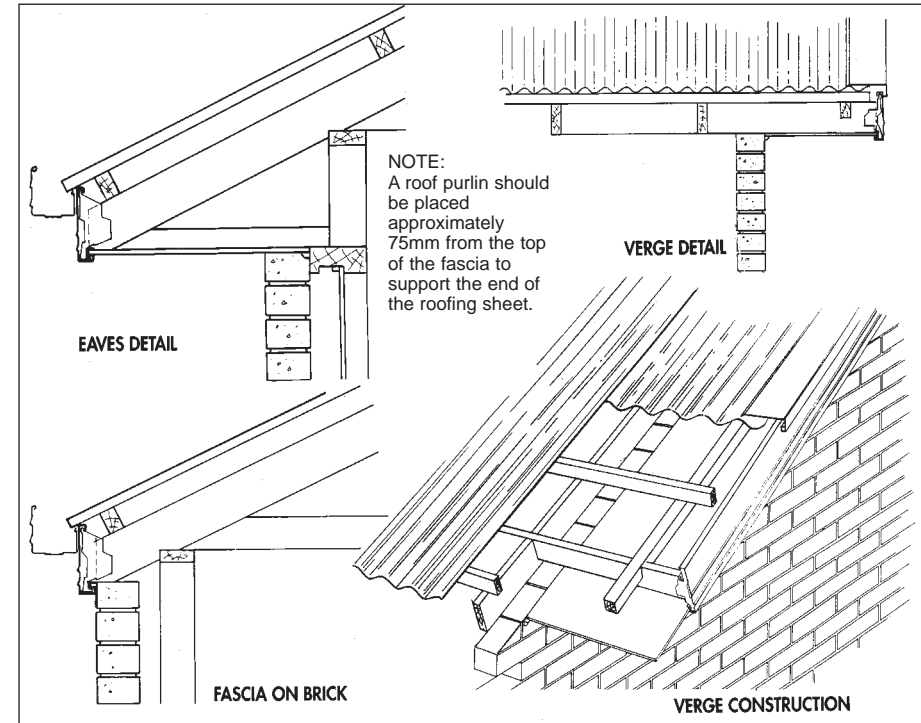

VERGE FRAMING

To ensure that your barges perform as required, it is important that thought has been given to the correct layout of roof framing for this area. Outriggers are generally required to support the weight of roofing extending past the wall line. The following details show how these trimmers should be installed:

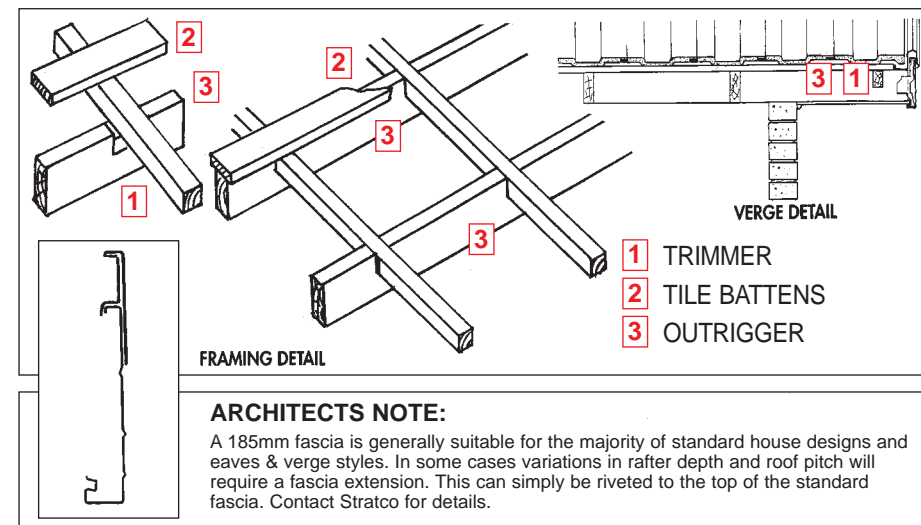

TOOLS YOU WILL NEED

MARKING OUT TOOLS

Square, string line, adjustable bevel square & spirit level.

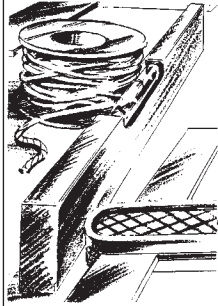

CUTTING TOOLS

Hacksaw, snips.

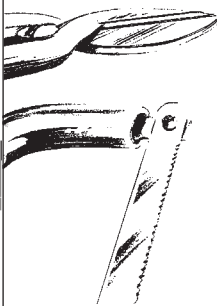

FIXING TOOLS

Hammer, drill, silicone, rivet gun pliers.



OTHER USEFUL ACCESSORIES

Ladder, scaffold.

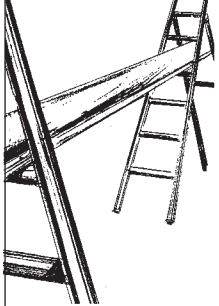

INSTALLING FASCIA

MEASURING YOUR PROJECT

- 1 Draw your roof outline and measure each fascia length required, marking it on your plan.
- 2 For lengths longer than 9 metres, allow a joining point adjacent to one rafter and mark the adjusted fascia lengths on your plan.

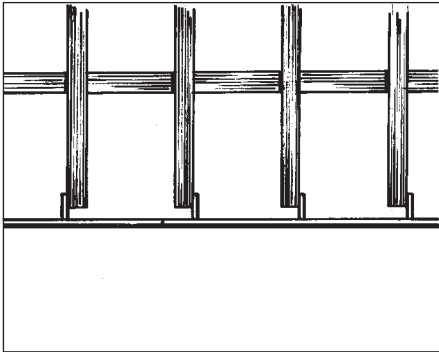

- 3 For internal corners not using butt joint method, measure past the corner (approximately 1 metre, and adjacent to a rafter) and mark the adjusted lengths on your plan. If the butt joint method is used lengths are measured to the actual corner.

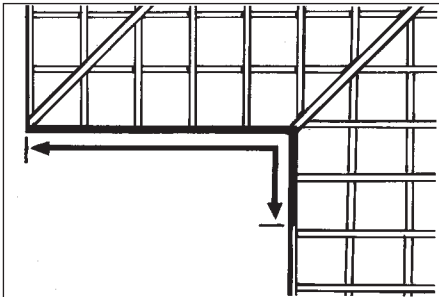

- 4 Measure barge by taking the actual roof length from the top of the apex to the bottom of the proposed fascia. Allow 300mm extra for laps and angle cutting.

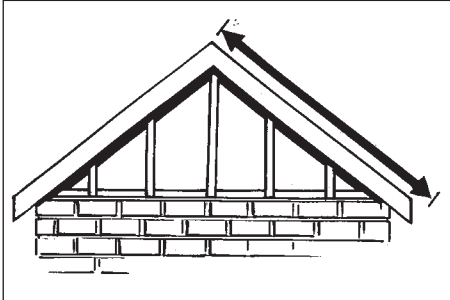

- 5 Complete your order form by summarising all fascia and barge lengths, counting internal and external mitres, and listing the number of brackets and other accessories required.
- 6 Phone or fax your order to your nearest Stratco outlet, clearly specifying delivery details and the fascia and gutter finishes required.

BEFORE YOU START

Ensure that all materials are on site and double check that the materials delivered correspond with your order and initial take-off. Ensure that all tools are on hand and that you have completely read and understood the Clickfast Fascia and Gutter installation instructions.

If further advice is needed contact your nearest Stratco Sales Office before commencing.

MARKING OUT

- 1 Check rafter foot and plumb cuts are correct.
- 2 Determine the eave height, by reference to the plans and by the location of soffit supports. The soffit should finish at the top of the window reveal, unless otherwise specified and the distance from the top of the top plate to the window reveal should be recorded (measurement A). Generally, this measurement should only be taken from the highest windows (usually the WC, laundry or bathroom). Check at least two windows to confirm the height.
- 3 Determine the distance from the back of the fascia base (by using a rafter bracket) to the outside face of the wall frame (measurement B). It is important to use a spirit level to ensure that the bracket is plumb in taking this measurement.

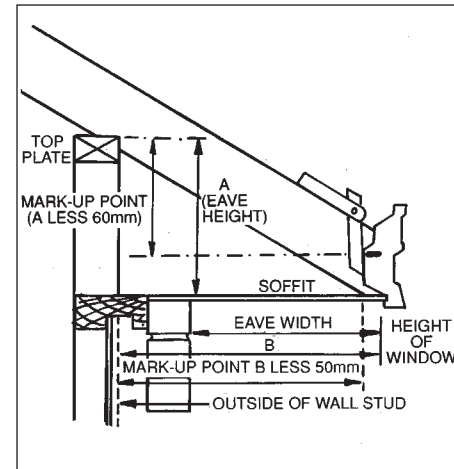

- 4 Deduct 60mm from measurement A and 50mm from measurement B to provide two mark out points for setting out a bracket. The mark out points determine the back of the bracket and the centre slot.

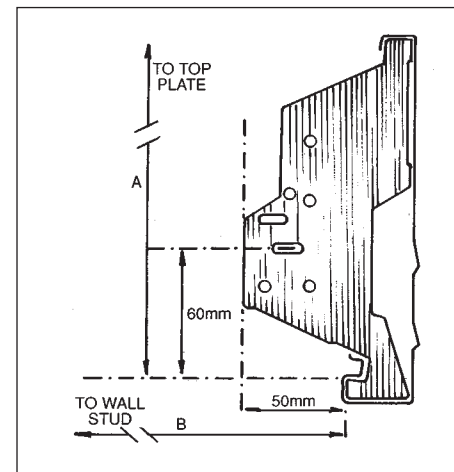

- 5 Using an adjustable bevel square, spirit level and tape, mark the bracket location on the second last rafter from each end of a fascia run. Nail a bracket (commencing with the first nail in the adjustment slot) to the inside of each rafter. Fully nail off each bracket with three nails.

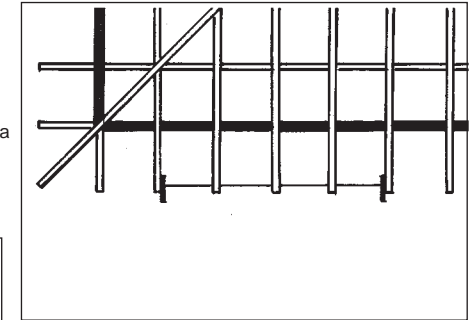

- 6 Place a nail into the foot cut of the rafter on the two brackets from Step 5, on the measurement B-50mm line and run a taut string line between them.

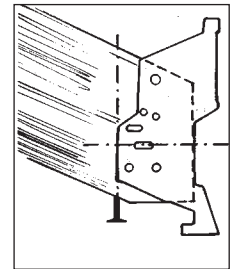

- 7 Using a bevel square, mark the location for the back of the bracket on every second rafter. Repeat this process around the building.

NOTE: An alternative method is to put the string line on the inside of the soffit groove on the bracket. To mark out the remaining brackets, use a loose bracket and the bevel square in conjunction with the string line. A final check is made using a spirit level against the bracket.

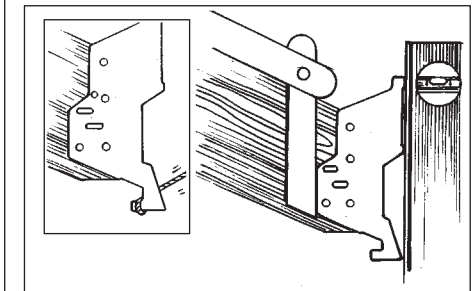
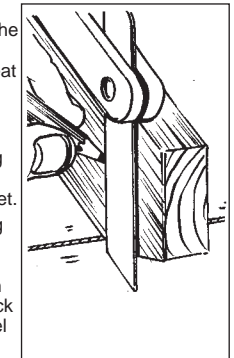

FASCIA INSTALLATION

- Slide the fascia onto one of the two brackets fixed (see 5 above).
 - Clip the base of the fascia into the second bracket.
 - Stretch the top of the fascia over the top of the bracket. In some cases, fascia can be simply slid over the second bracket.

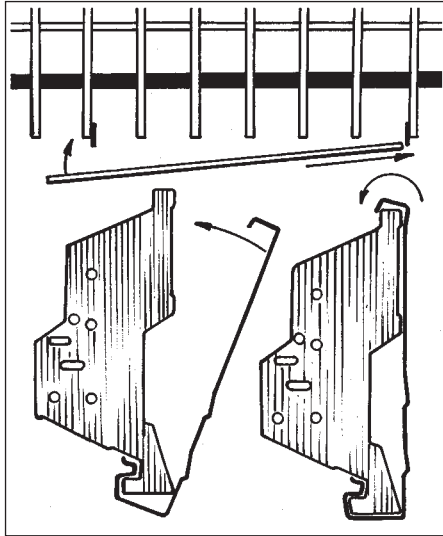

- At the centre point of the run, insert a bracket into the fascia and then fix the bracket to the set up point previously marked (Step 7 previous page) with a nail in the centre slot only.
- Check the fascia for straightness (by eye) by looking along the base of the fascia (also check with spirit level to base of fascia). When straight, fix every second rafter to the set up lines marked, again using the centre slot and now utilizing one of the base holes. Ensure that the base of the fascia stays straight.

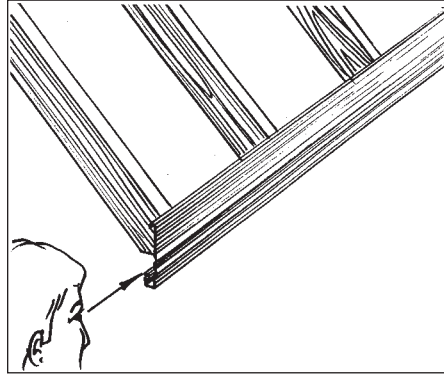

- Finish nailing all marked brackets and then all brackets not previously installed.
- Install hip rafter brackets remembering to fold the top tag over the rafter and nail.

INSTALLING ACCESSORIES

JOINING SLEEVES

- Where a joining sleeve is required, do not fully nail standard rafter brackets for at least two rafters adjacent to the join.
- Rivet the joining sleeve to one length of fascia as shown.

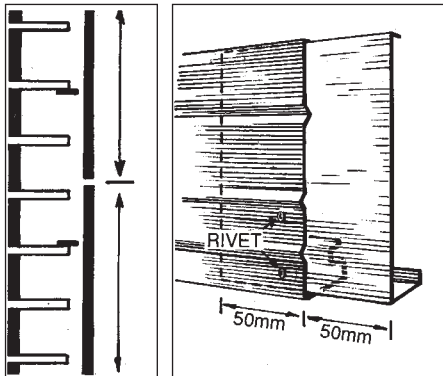

- Slide the second piece of fascia over the joining sleeve and rivet.
- Check that the fascia is straight by sighting along the base of the fascia and nail the remaining brackets.

EXTERNAL MITRES

- Slide the external mitre over the adjoining fascia and check that the fascia has not been pulled out of line and that the corner remains square.
- Rivet the external mitre at the 'dimples' embossed in the mitre. Recheck for square and alignment.

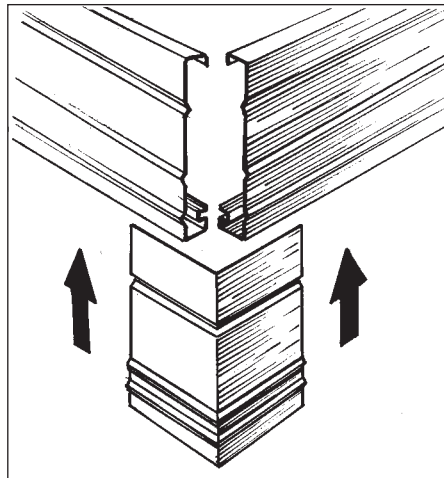

INTERNAL MITRES

- Measure the fascia from the inside of the nearest external corner or joining sleeve to the proposed position of the internal mitre.
- Cut the top lip of the fascia and the base with a hacksaw and bend to 90°.

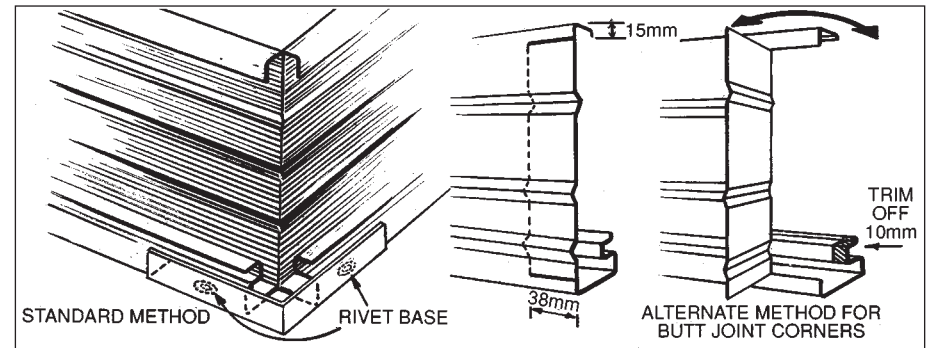

- Fix the fascia to the brackets on the long run in the same manner as previously described.
- Ensuring that the internal corner remains at 90°, fix the rafter brackets to the short run of fascia.
- Attach the internal corner with rivets as shown. Note that the alternate butt joint method still requires an internal corner mitre.

INSTALLING FASCIA AS BARGE

MARKING OUT

- On the barge rafter bracket, the centre slot is set 52 mm from the base of the outrigger and the back of the bracket is set in 50 mm from its end.

FIXING BRACKETS

- Fix only two brackets as previously described using three nails on each side of gable.

INSTALLING

- The first length of barge to be installed must first have the lower end made to fit the fascia.

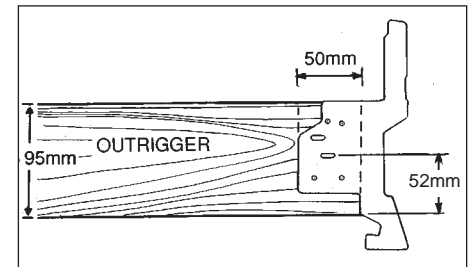

This is done by:

- Marking on the front of the barge the roof pitch and then cut off.
- On the cut edge, mark down 185 mm, and then draw a line at 90° from the base to intersect this point, then cut this off.
- On the cut edge, mark a line at 90° at the intersection of the two previous steps. This line will go to the base of the fascia.
- Cut along the line marked in the previous step. Also cut excess metal from below soffit groove (trim this groove to length if needed). Push upwards and rivet.

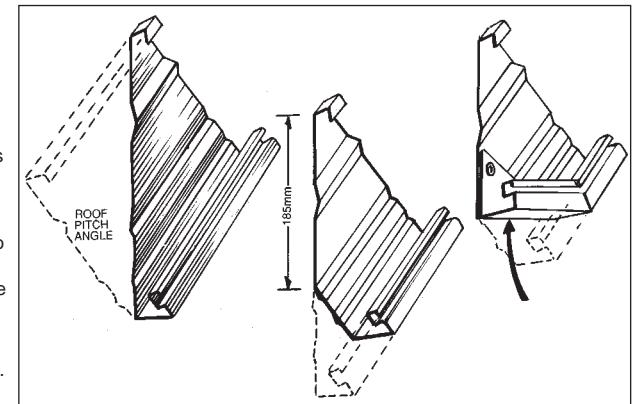

- Attach barge as previously described for fascia.
- Attach barge mould as per external mitre (remember that the long leg of the barge mould fits on the fascia. Both left hand and right hand barge moulds are available).
- Install remaining barge rafter brackets.

5 Cut barge vertically at apex. The second length of barge to be put up is done in a reverse manner. This is done by:

- Cut barge vertically to suit apex on the ground.
- Install barge as per previous length.
- Mark length against fascia.
- Remove the second piece of barge.

- Modify end to suit fascia as per previous length.
- Re-install barge.
- Attach barge mould as per previous.
- Install remaining barge rafter brackets.
- Install barge apex cover by pushing up from bottom, rivet to barge and trim excess.

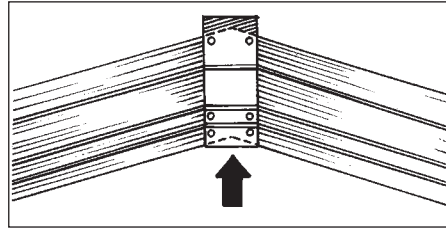
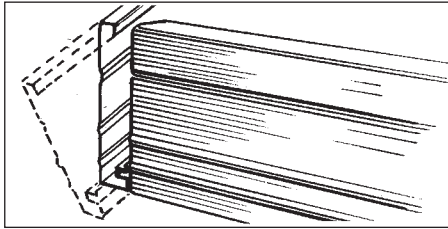

PREPARING AND INSTALLING BARGE GUTTER

1 On the apex end of your barge gutter, set an adjustable bevel to the roof pitch, mark a line up the front of the barge gutter, continue the line over the crest of the gutter, across the pan and up the short side, again using the roof pitch.

2 Cut along the lines to remove the excess material.

3 Repeat the above process, drawing a second line 10mm from the cutting line, this allows a lap to join the two lengths together at the apex later. (This length has a joining line marked on it).

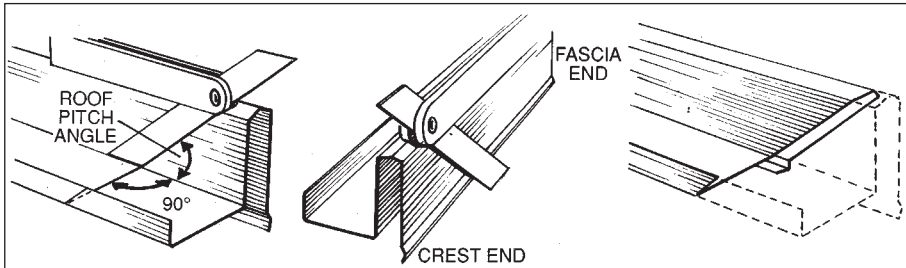

4 Measure the barge from the apex cut to the outside edge of the fascia.

NOTE: Where your barge gutter reaches the eaves gutter, the barge gutter is below the level of the back of the eaves gutter. To rectify this simply follow these steps.

- From the base of the barge gutter, allow a 10mm lap then mark a second line 50mm above the first (note: make sure to leave at least 10mm from the top edge to join together).

To maintain a downward water flow to the gutter:

- Mark and cut as shown in the drawing.
- Fold the base up and rivet and silicone joints. Please note that the vertical edge may need to be trimmed to suit tiles.
- Repeat for remaining lengths.

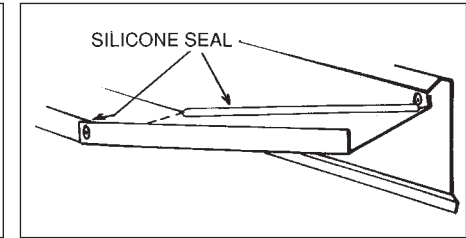
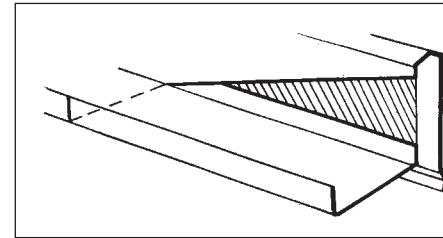
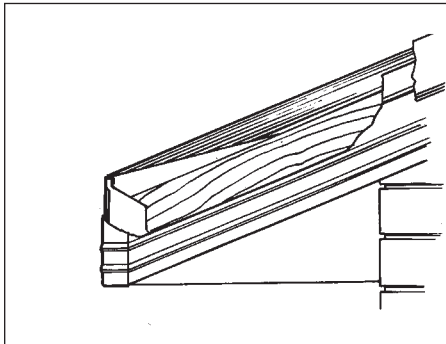
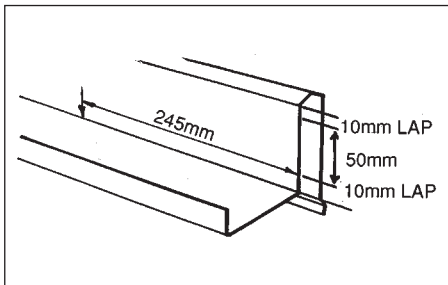

5 Install the first length of barge gutter (that has no allowance for joining at the apex) ensuring it sits parallel to the barge.

- Rivet the barge gutter to the barge at approximately 900mm centres just above the rib.

Install the second length of barge gutter and at the apex, where the two lengths meet, bend the laps down to meet the first length of barge gutter, rivet and seal.

CLICKFAST® GUTTER INSTALLATION

NOTE: Most gutter profiles produced by other manufacturers cannot be used in conjunction with the Stratco suspension clip.

1 In the middle of a run of gutter and fascia, two suspension clips are installed onto the fascia, approximately 1200mm apart.

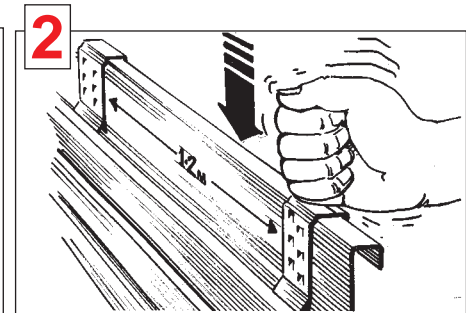
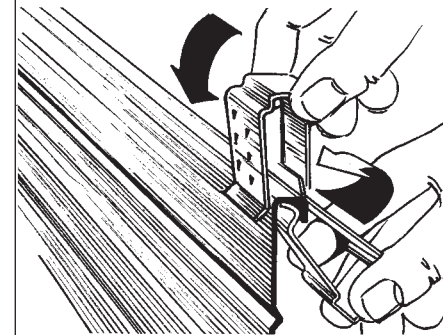

4 NOTE: When joining gutter lengths, always make sure that the water flow runs down the lap.

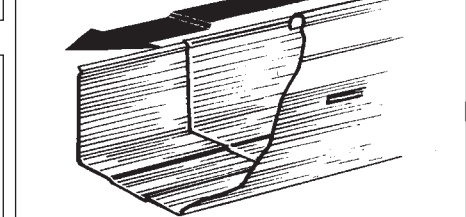

3 The gutter is lifted until the suspension clip engages the back of the gutter to hold it in position.

Falling the gutter to the water outlets is achieved by "clicking" the gutter up to the top tooth at the point furthest away and to the second lowest tooth near the water outlet.



5 Internal gutter straps are rolled into the front bead and then bent over the back of the fascia. These are also placed at approximately 1200mm spacing.

