

INSTALLATION GUIDE



Flat Roof Homesheds™ THE POTTER



BEFORE YOU START

It is important to check your Local Government Authority requirements before the installation of your new Stratco Potter Flat Roof Homeshed. Read these instructions thoroughly before starting your project and refer to them constantly during each stage of construction. Contact Stratco for advice if you do not have the necessary tools or information.

Before starting, lay out the main components in order of assembly on the ground and check them against the delivery note. The 'Components' section identifies each part of your Potter Flat Roof Homeshed.

Ensure there is reasonable access for materials and working space, ensure the shed site is level and consider the disposal of run-off water.

TOOLS REQUIRED

All tools are available from your local Stratco H.I.S.

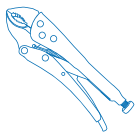

Multi- Grip Pliers

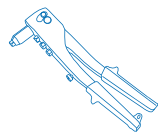

Rivet Gun

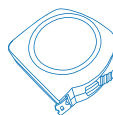

Tape Measure



Phillips Head Adapter

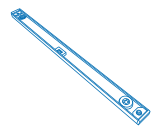

Spirit Level

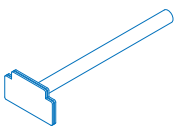

Turn Up/Down Tool

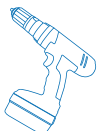

Power Drill

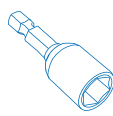

5/16" Hex Head Adapter



Permanent Marker

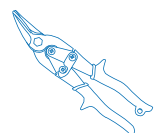

Tin Snips



1/8" Drill Bit



Gloves



Safety Glasses



Step Ladder

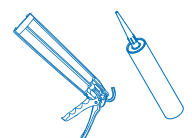

Silicone Gun / Silicone



COMPONENTS

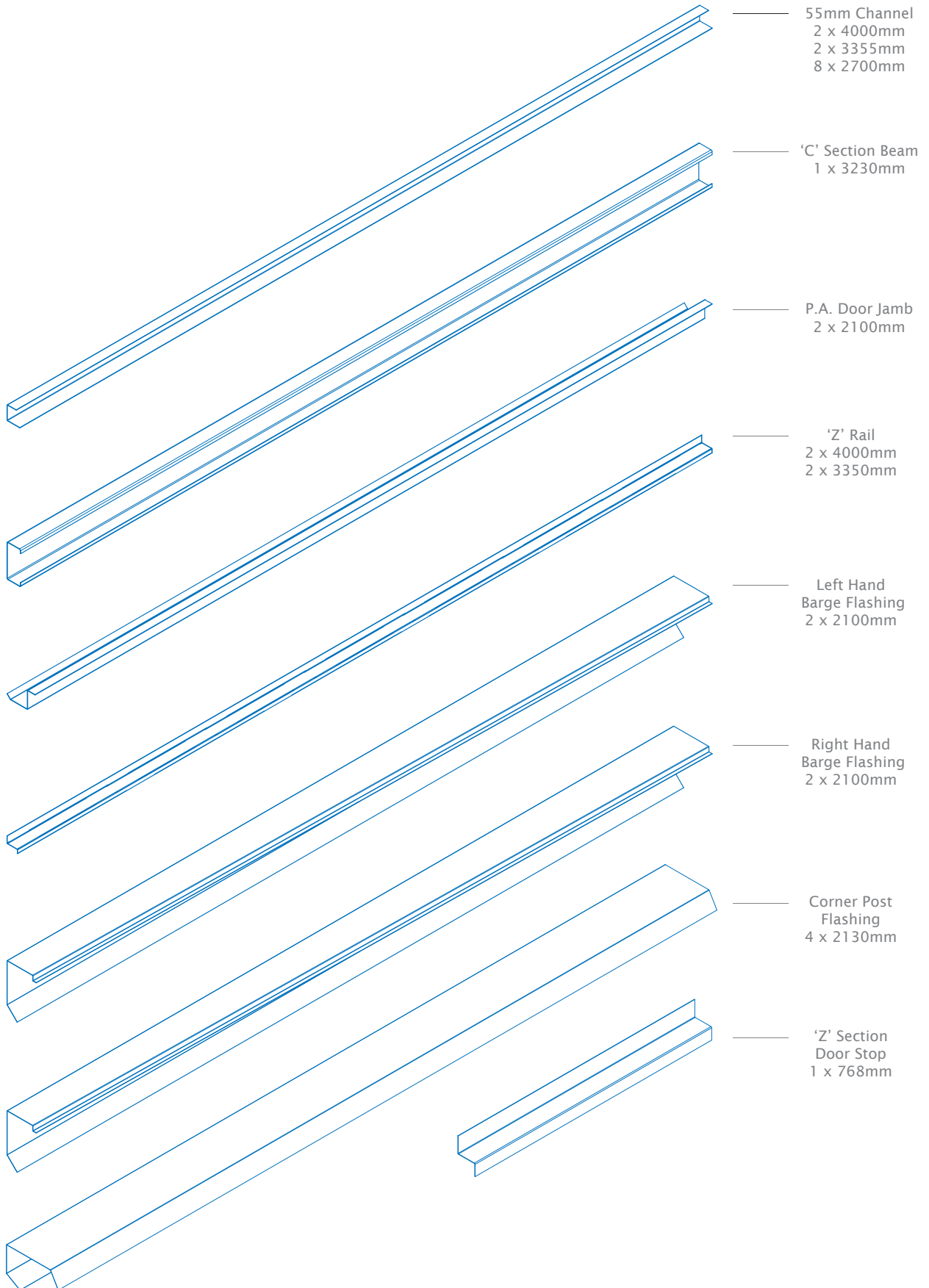

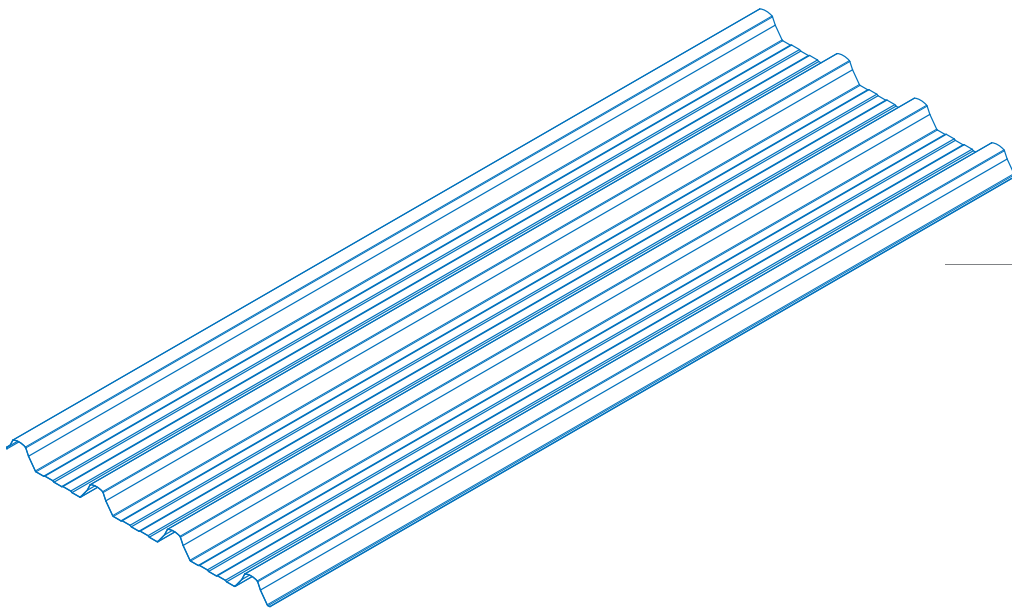

Prodek®
5 x 4200mm
21 x 2100mm

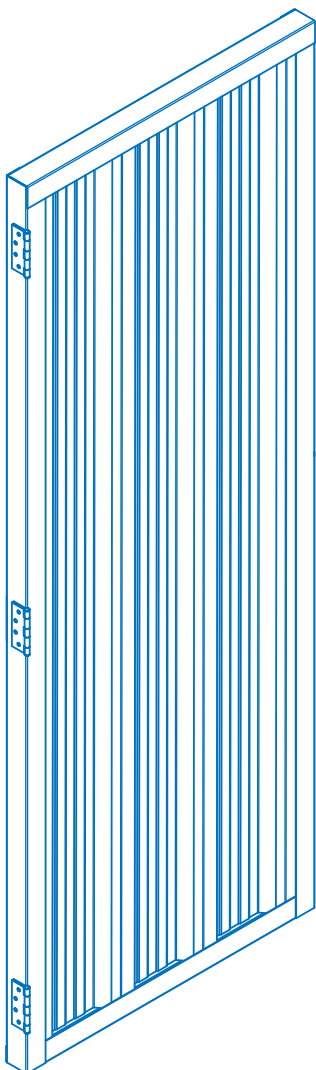

P.A. Door
1 x pre-assembled

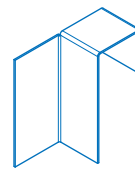

End Fix Bracket
1 x Left Hand

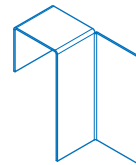

End Fix Bracket
1 x Right Hand



10x16 screws
x 120



Rivets
x 270



Wafer Head
10x16 screws x 12

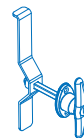

T-Handle
x 1

Note: the components listed are for a standard shed, components will vary depending on options. Refer options in the back of the instructions.



STEP ONE

Set out accurately the footing hole locations and check all dimensions before attempting to dig holes. Note: Door can be positioned on any wall panel by lapping a sheet.

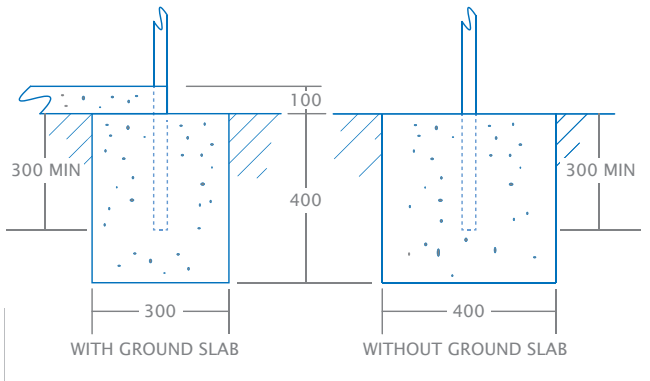

Footing Details

Dig post holes using a post hole digger and spade. Refer footing details above. Footing details show minimum depth, trim posts to suit or increase depth of footing as required.

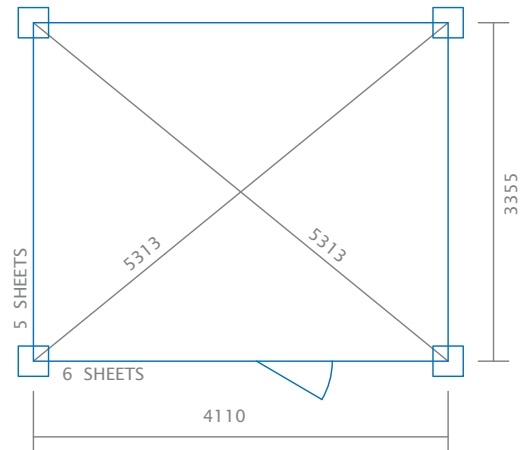

Footing Layout

Footing sizes assume a firm natural sandy clay soil. Increase depth by 150mm for firm natural sandy soil.

STEP TWO

Layout on the ground the components for one complete side panel frame with single wall sheet as shown below.

- 4 x 2700mm - 55mm Channel
- 1 x 4000mm - 55mm Channel
- 1 x 4000mm - 'Z' Rail
- 1 x 2100mm - Prodek sheet
- 1 x End fix bracket

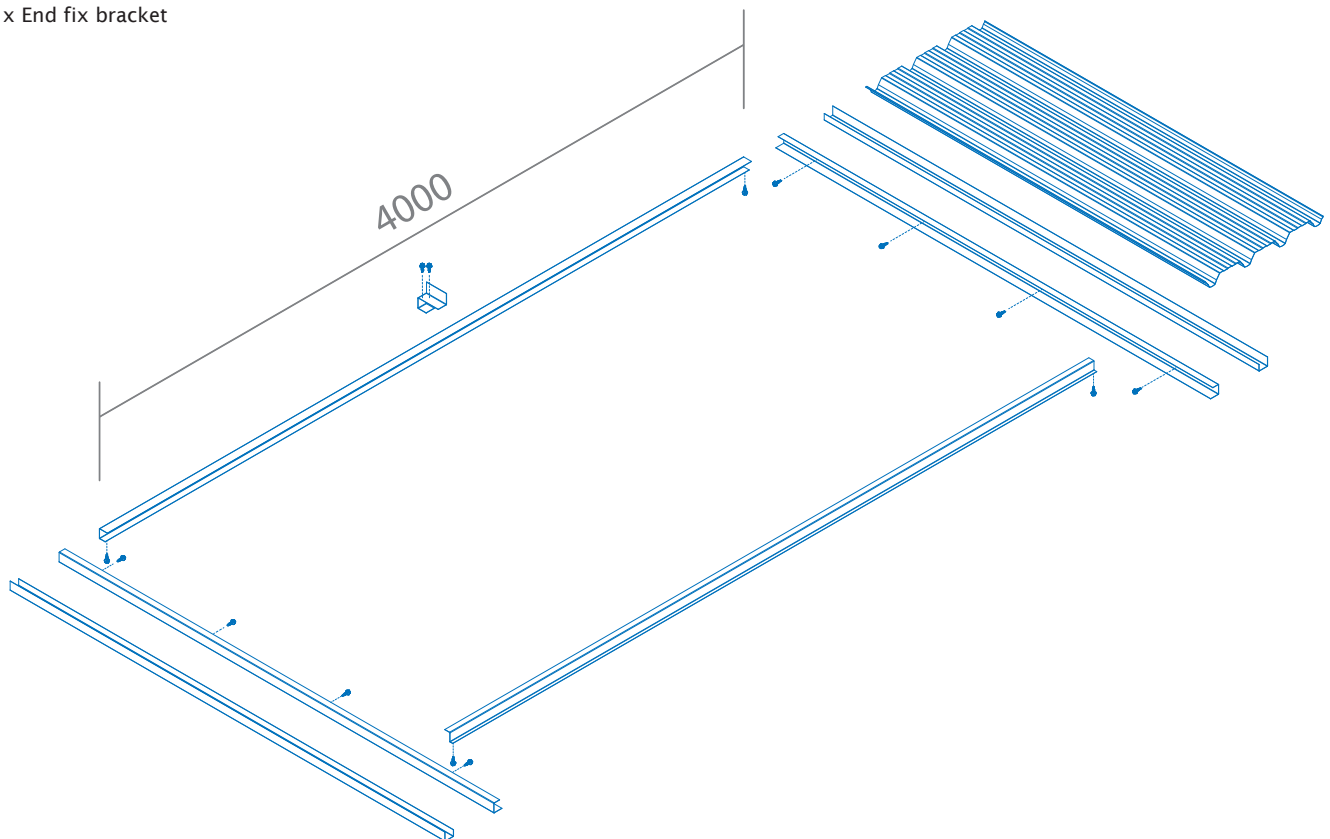

Panel Layout

STEP THREE

Run a bead of silicone along one of the 2700mm long 55mm channels making sure the bead is on the short leg. Place against the back of another 2700mm length of 55mm channel and screw together (Figure 1). Repeat for the opposite corner post (Figure 2). With two 10x16 screws attach the 4000mm top channel to the corner posts (Figure 3). With two 10x16 screws attach the Z rail

2110mm from the top channel with the long leg inward (Figure 4). To assist in maintaining panel squareness install one Prodek sheet (Figure 5), refer to Step 8 for fixing details. Attach the End Fix Bracket to the top channel, mid-span with two 10x16 screws (Figure 6).

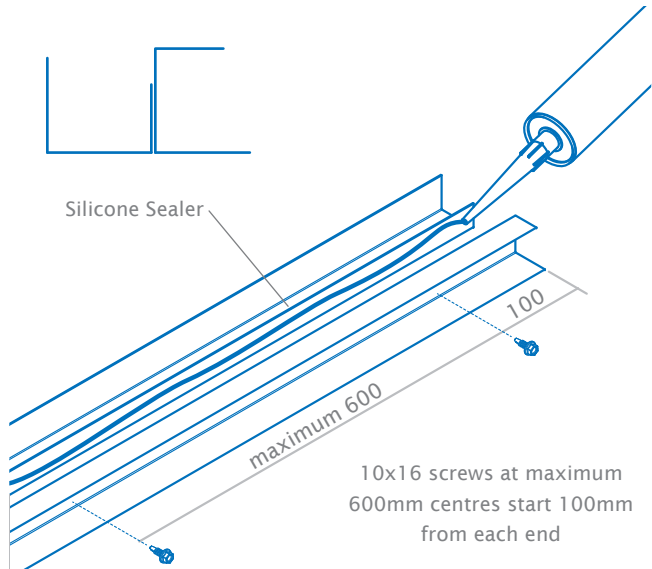

Figure 1

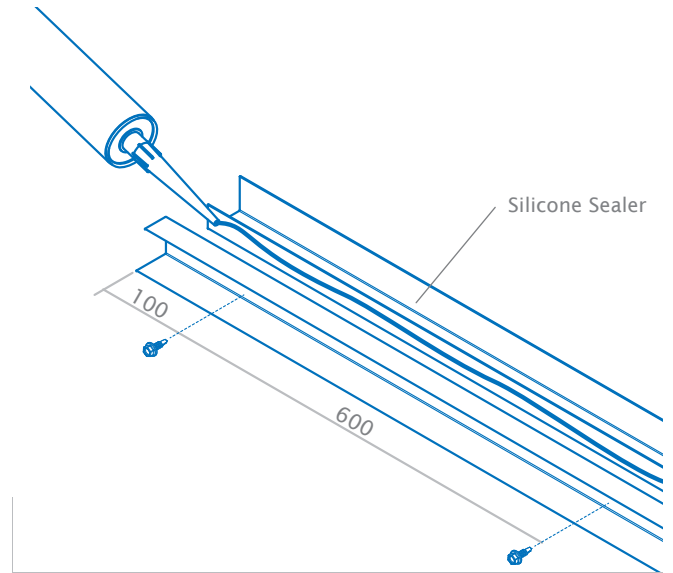

Figure 2

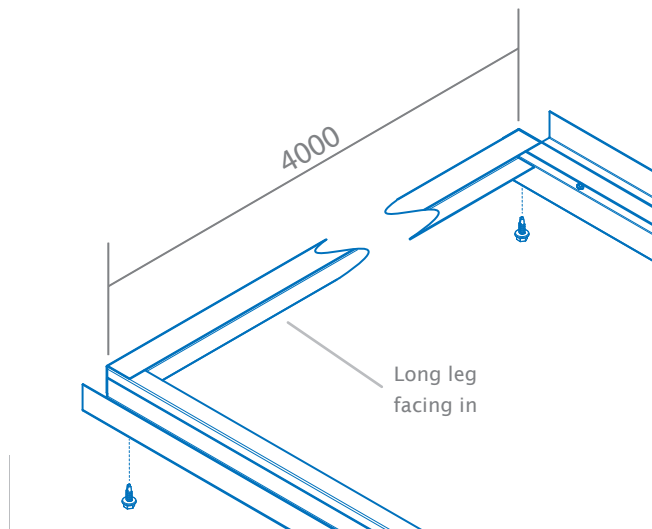

Figure 3

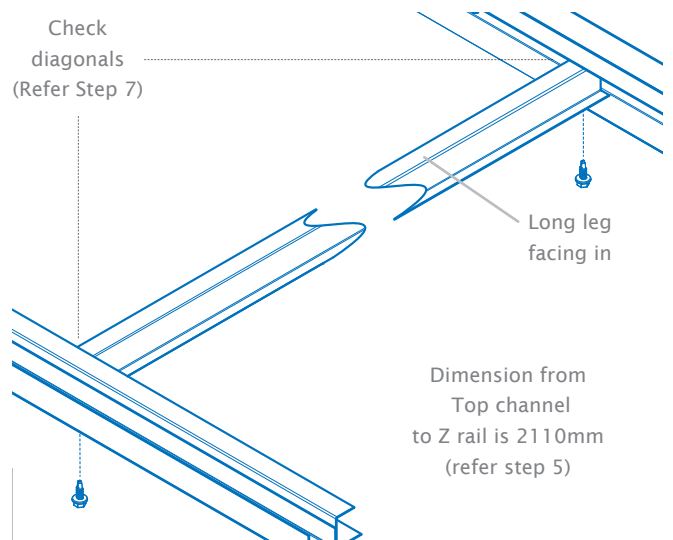

Figure 4

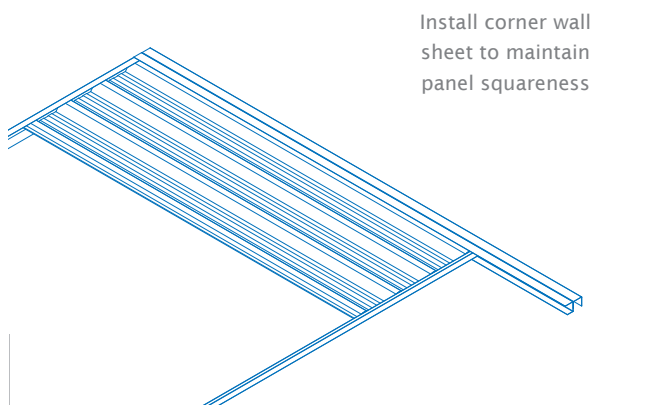

Figure 5

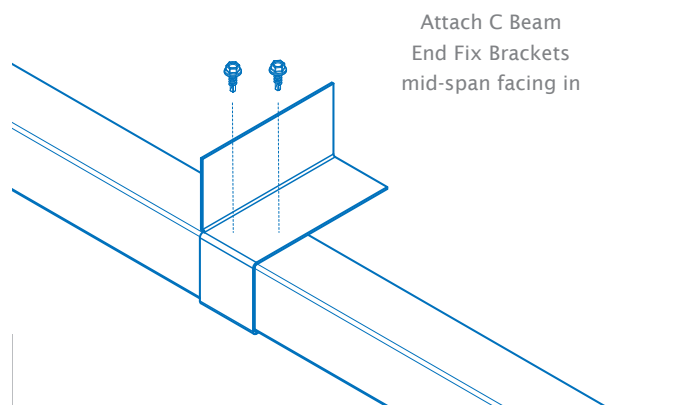

Figure 6



STEP FOUR

Layout the second side panel and repeat steps two and three.

STEP FIVE

Carefully lift up one panel and place in holes. Secure with temporary supports. Repeat this operation for the other panel. Place a bearer (e.g. an old brick) in the bottom of each hole to prevent the posts penetrating through the soil. Place the two remaining 55mm channels on top of the corner posts with the long leg inward and

attach with 10x16 screws. Place the two remaining Z rails 2110mm from the top channel with the long leg inward and attach with two 10 x 16 screws. Ensure the Z rails are level with the Z rails previously installed.

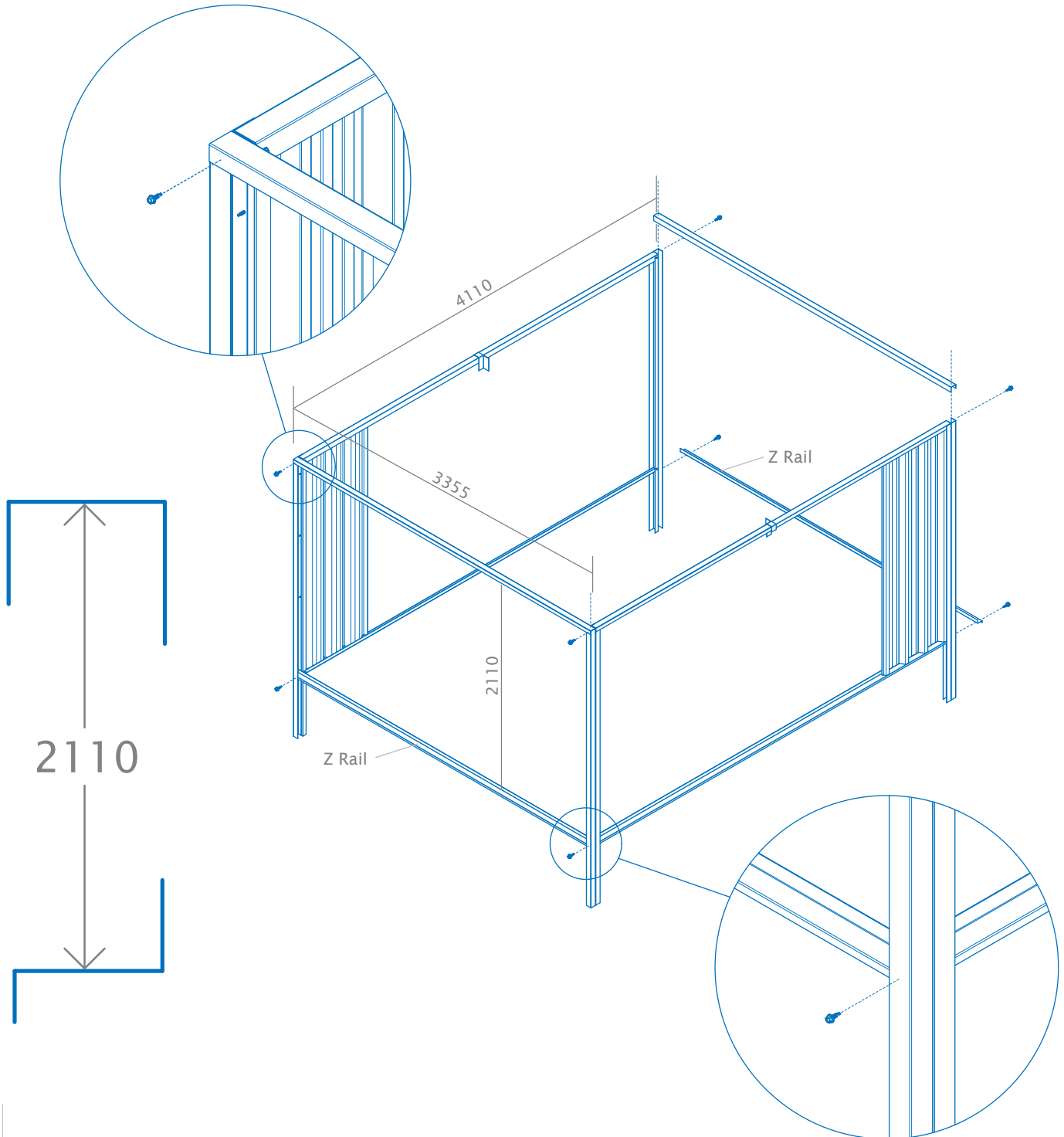

STEP SIX

Lift the C section beam into place and temporarily support while ensuring the bottom of the end fix bracket is touching the bottom inside of the C section beam (Figure 7). This provides the correct

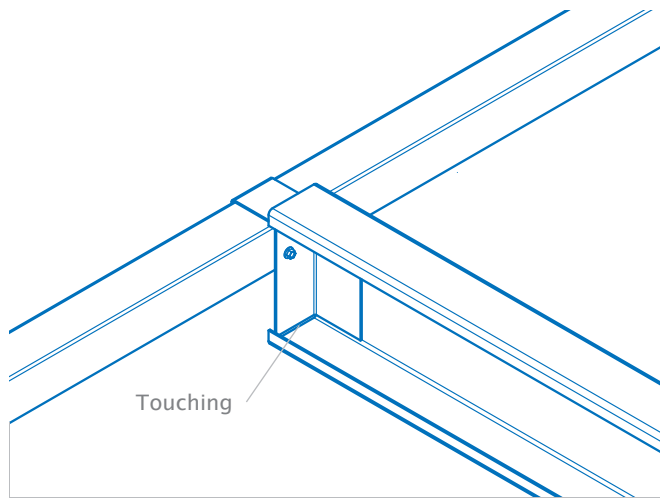

Figure 7

height for the slope of the roof sheets. Fix the C section beam to the brackets using three 10x16 screws per bracket (Figure 8).

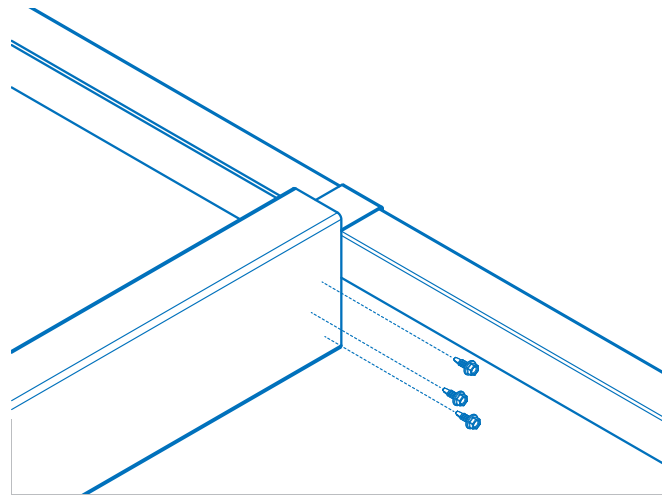
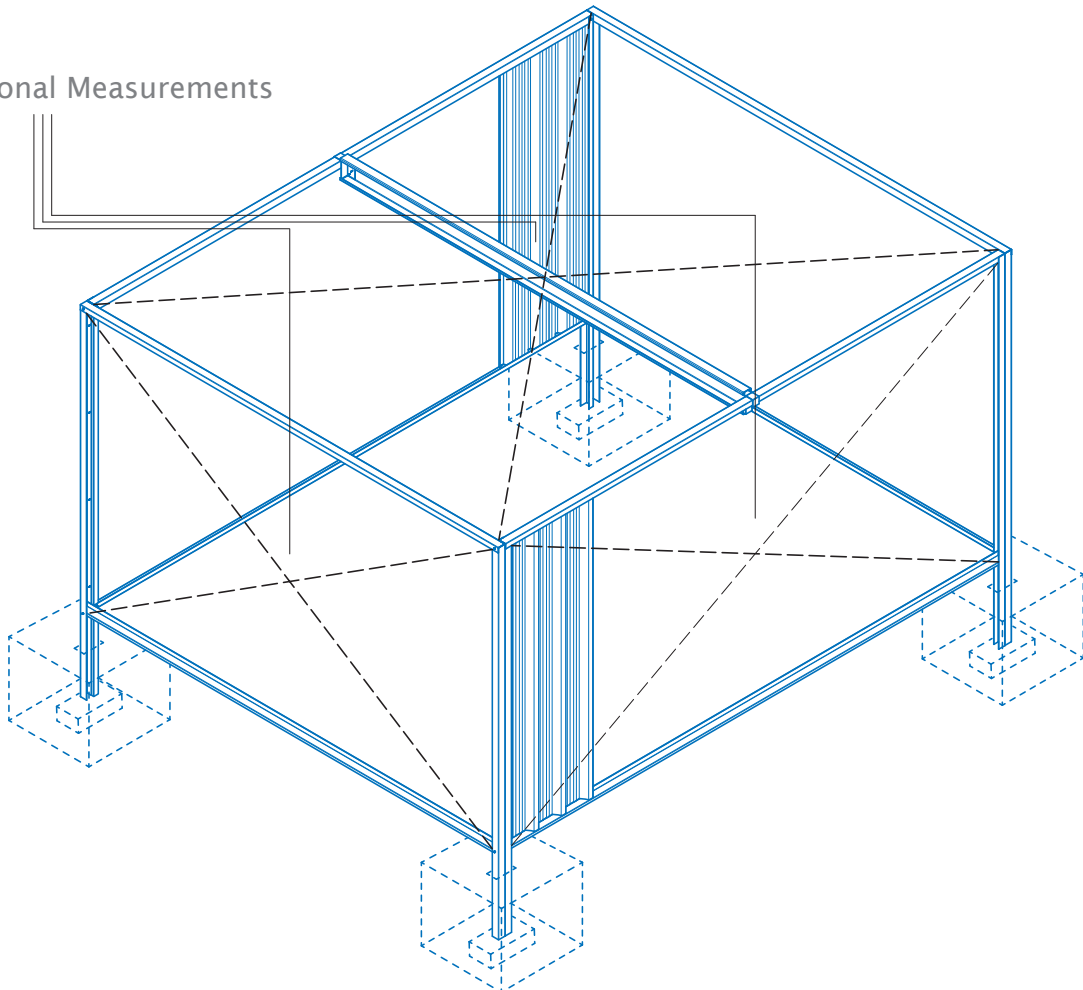

Figure 8

STEP SEVEN

Inspect all connections and all members for squareness and levels. Once you are satisfied proceed to place concrete around all posts. Use temporary bracing to maintain squareness while concrete sets.

Check Diagonal Measurements



Diagonal Measurements



STEP EIGHT

Locate your position for the P.A. door, the example provided is for a left hand hung door approximately $1\frac{1}{2}$ sheets from the corner post (Figure 9). Note: Do not position door directly below C-section support beam or gutter. The space for the P.A. door can be created by half lapping one sheet over another full sheet. To eliminate cutting sheets it is recommended you temporarily locate both jambs in their approximate positions. Lay the wall sheets on the ground lining up all sheets with the intended position of the P.A. door. Proceed to install the wall sheets from the corner post working toward the door jamb from which the door will be hung (Figure 10). Refer lapping detail (Figure 42). Secure sheets with one rivet per crest at the top, two rivets per pan at the base and one rivet mid-span at the join between sheets (Figure 11). The Z rail base should be temporarily supported during this step.

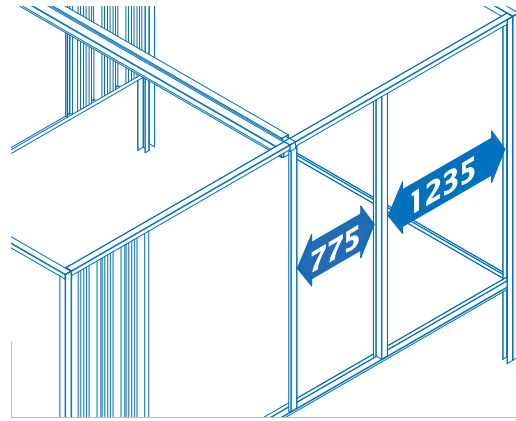

Figure 9

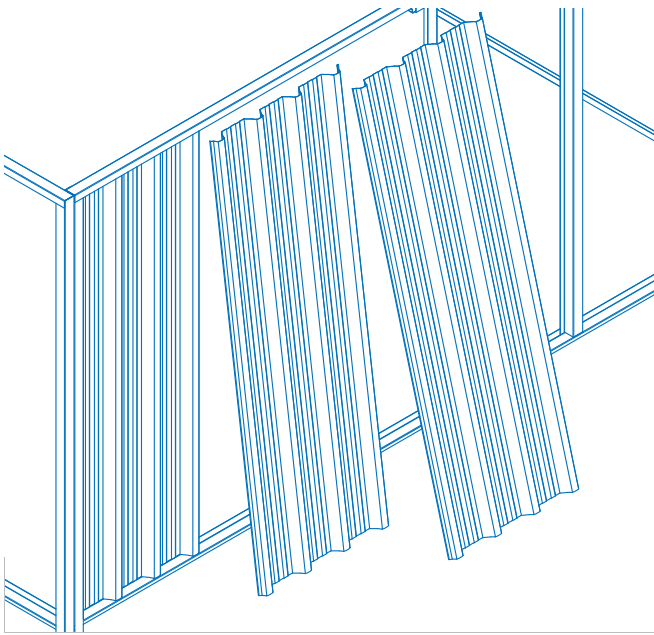

Figure 10

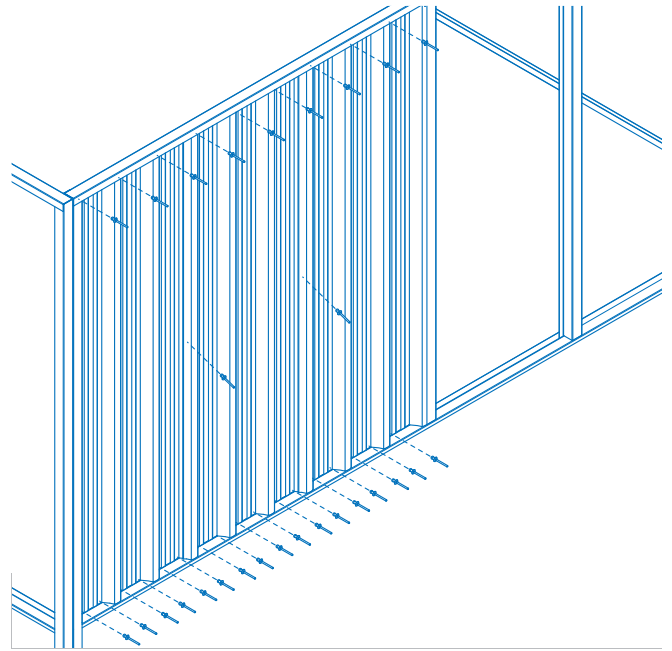

Figure 11

STEP NINE

Remeasure the door jambs and adjust if necessary (Figure 9). Install the remaining wall sheets working from the other corner post toward the door jamb (Figure 12). Half lapping one sheet over

another full sheet (Figure 42). Secure sheets with one rivet per crest at the top, two rivets per pan at the base and one rivet mid-span at the join between sheets (Figure 13).

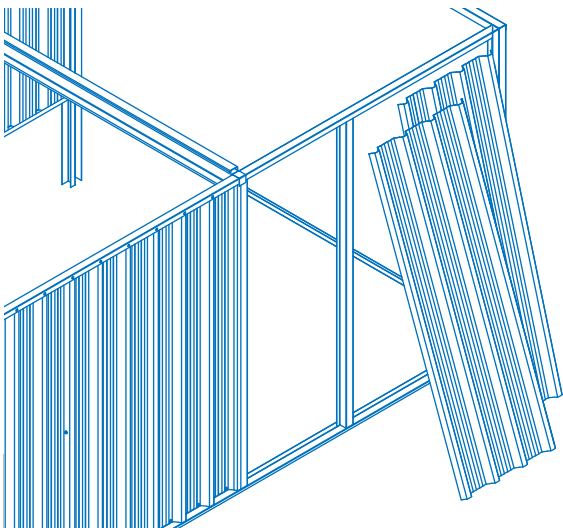

Figure 12

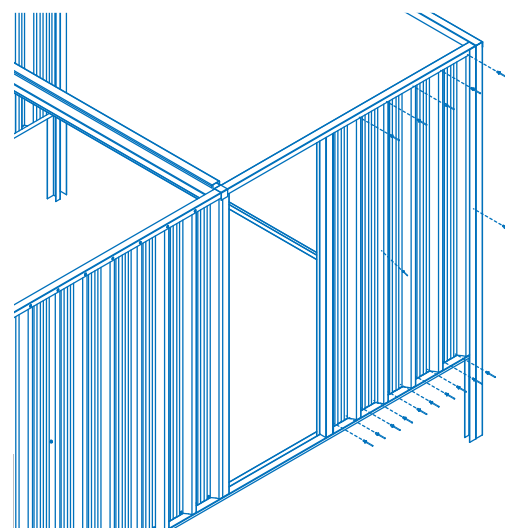

Figure 13



STEP TEN

Remeasure the door jambs and adjust if necessary (Figure 9). Install the door jamb from which the door will be hung, using a 10x16 screw attached to the top channel and a rivet attached to bottom Z rail (Figure 15). Position the door and fix to the jamb using four 10x16 wafer head screws per hinge (Figure 16). Close the door and check the position of the unfixed door jamb, before fixing ensure the Z section door stop will fit (Figure 14). Install remaining door jamb (Figure 15). Insert Z section into top channel and attach with four rivets (Figure 14).

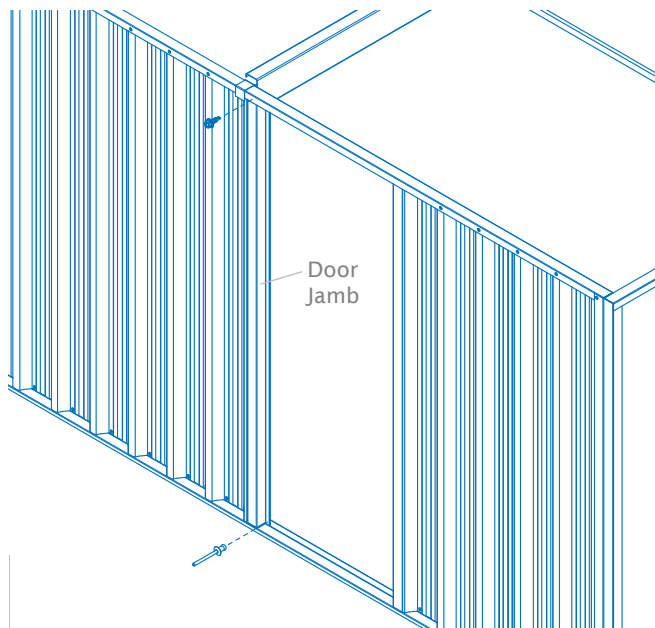

Figure 15

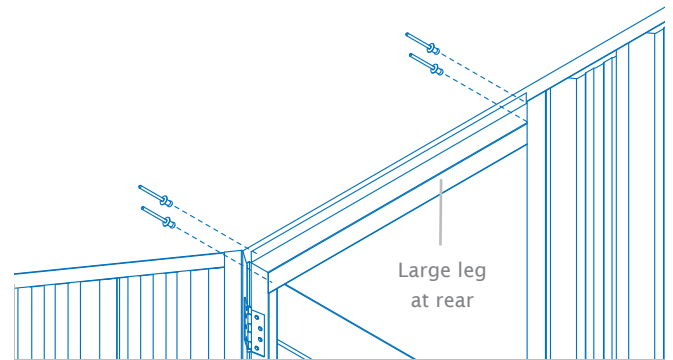

Figure 14

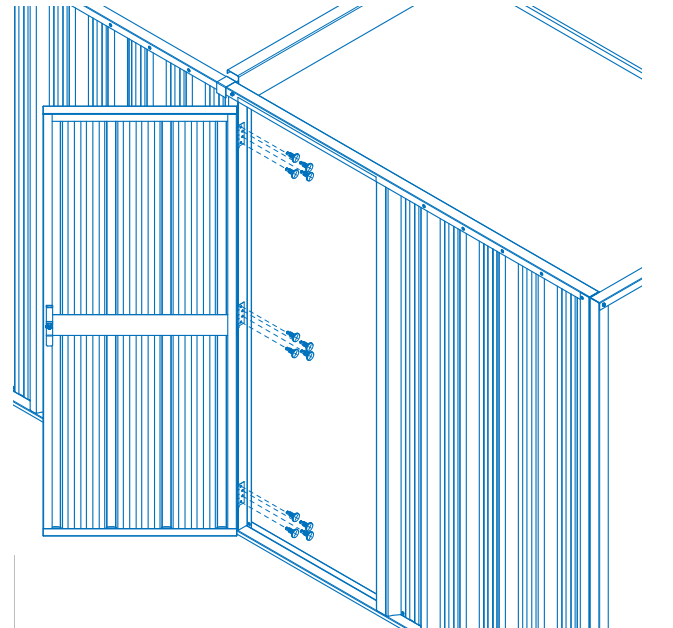

Figure 16

STEP ELEVEN

Start the installation of the wall sheets from the rear corner and work forward. Before fixing wall sheets trial layout sheets in the panel to ensure last sheet fits correctly into the corner. Correct spacing of the wall sheet can best be achieved by marking top and bottom tracks and fixing sheets to these marks. Z rail base should be temporarily supported to take out any bowing while installing

wall sheets. Secure sheets with one rivet per crest at the top, two rivets per pan at the base and one rivet mid span at the join between sheets. Refer to sheet fixing details (Figure 42). Ensure all wall sheets are secured with rivets into corner channels and door jambs top, bottom and mid-height. Optional dust proofing can be installed after Prodek.

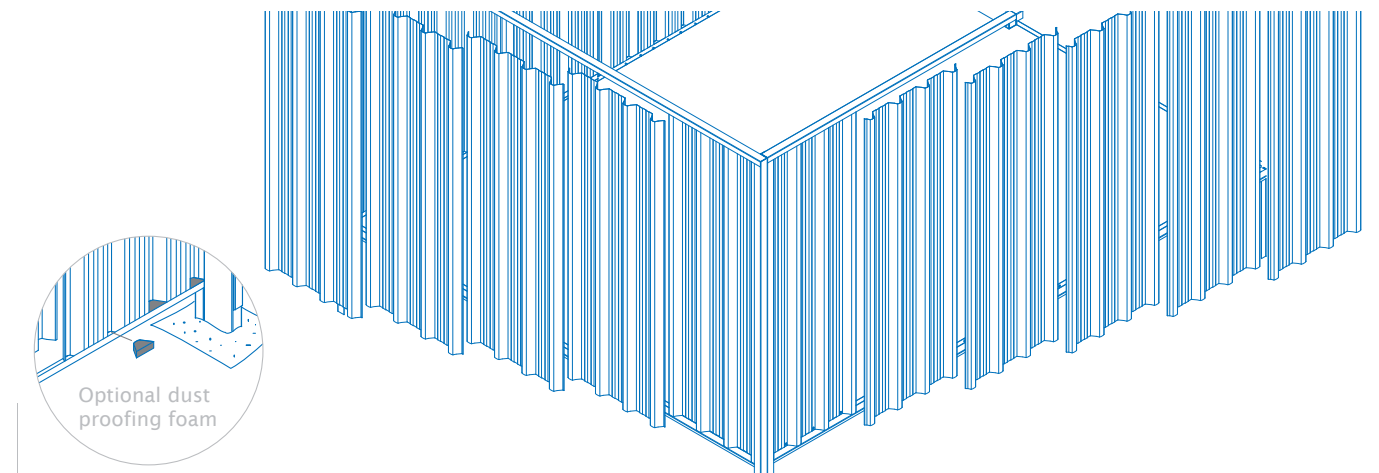

Figure 17



STEP TWELVE

Position the corner post flashing ensuring the bottom edge is sitting on top of the bottom Z rail (Figure 18). Trim the top of the corner post flashing as required (Figure 20). Secure flashing with rivets at maximum 500mm centres each side starting 20mm from each end. (Figure 19). Repeat for all corners.

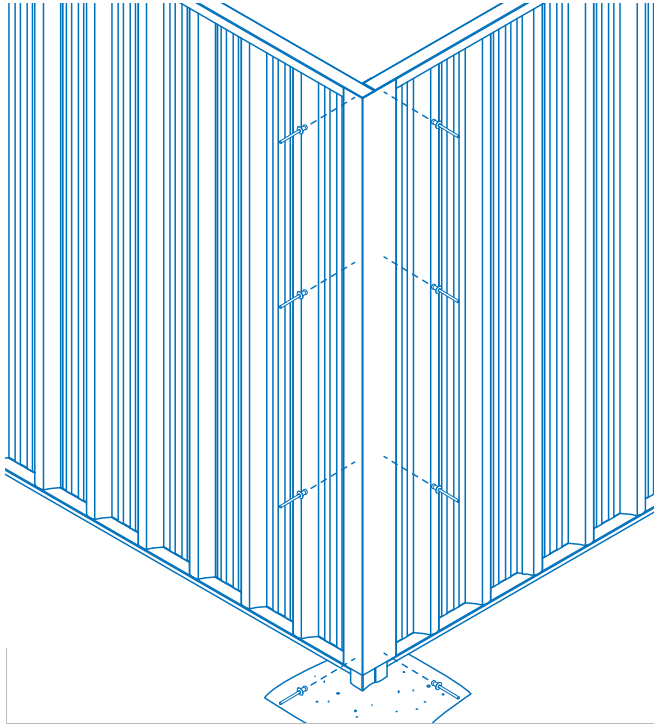

Figure 19

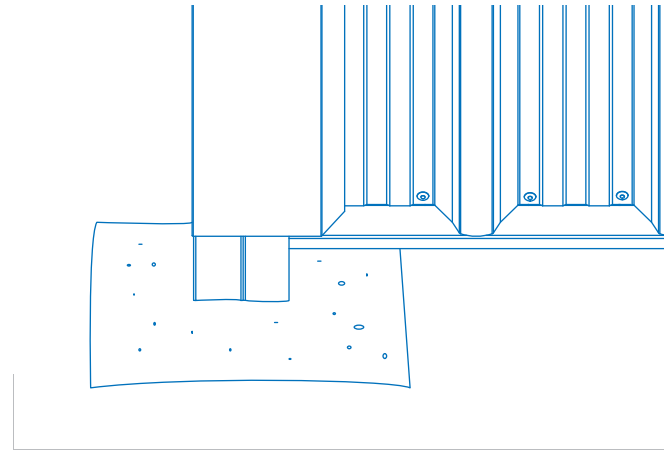

Figure 18

Trim with
tin snips
if required

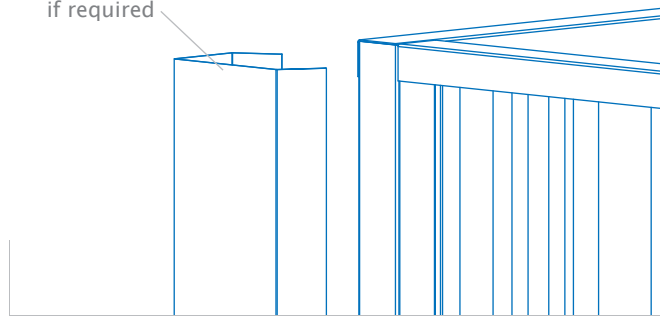

Figure 20

STEP THIRTEEN

Note: If you have purchased the gutter option, refer to the Gutter Option section of the instructions before completing Step 13. Before laying the roof sheets pans must be turned down at each end 45° to the horizontal (Figure 21). Optional dust proofing foam can be placed between Prodek and top channel (Figure 22). Place the Prodek roof sheets on the C section beam. Start laying the sheets from the outside edge of the top channel on the long side. Installing one sheet at a time, fix using one 10x16 screw per pan into C section beam and top channels (Figure 23). Refer sheet fixing details (Figure 42). If translucent sheeting is used ensure at least one steel sheet is secured each side. Translucent sheeting is not to be walked on.

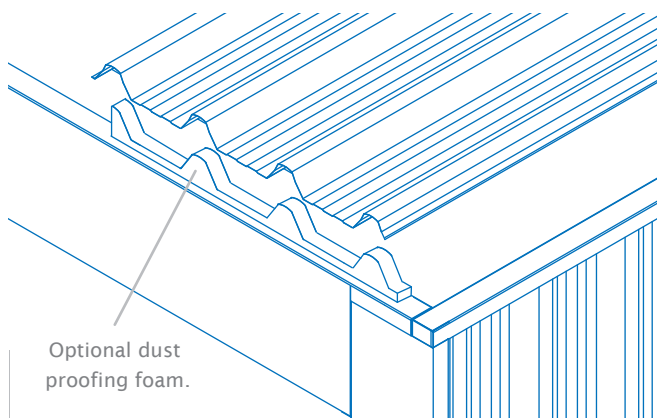

Figure 22

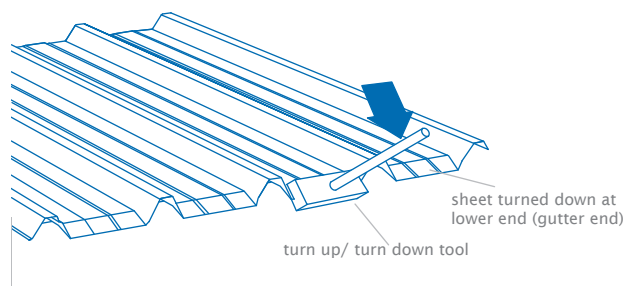

Figure 21

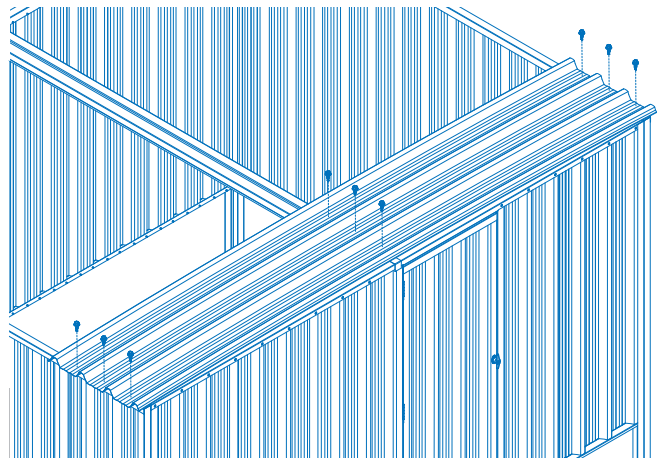

Figure 23

STEP FOURTEEN

Note: If you have purchased the gutter option, refer to the Gutter Option section of the instructions before completing Step 14. Make a mark mid span on the top of the first crest of the roof and position left hand barge flashing so the end is minimum 5mm past the mark. Fix with two 10x16 screws (Figure 24). Position the right hand barge flashing so the ends overlap by minimum 10mm. Fix

two more 10x16 screws into top channel (Figure 25). Fix a 10x16 screw mid-span so that it penetrates both barge flashings and the first crest of the roof sheet. Fix two more 10x16 screws at either end again penetrating the crest of the roof sheet (Figure 25). Repeat the procedure for the opposite side.

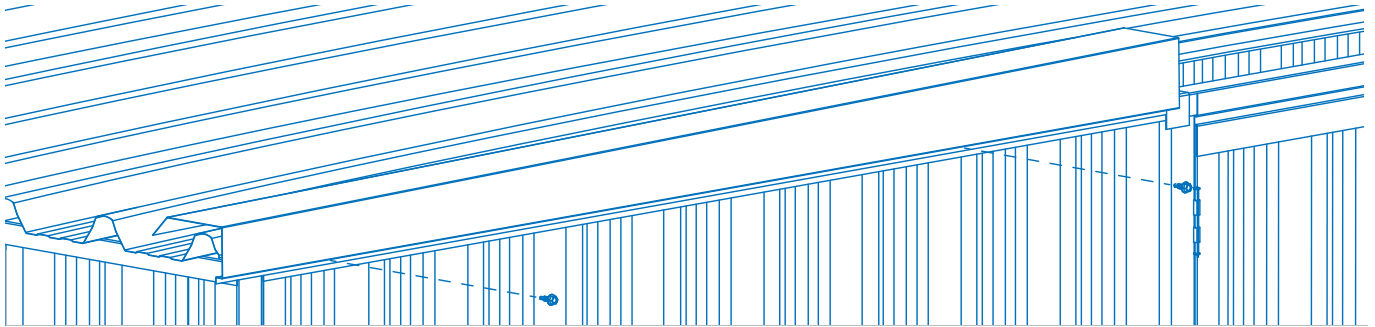

Figure 24

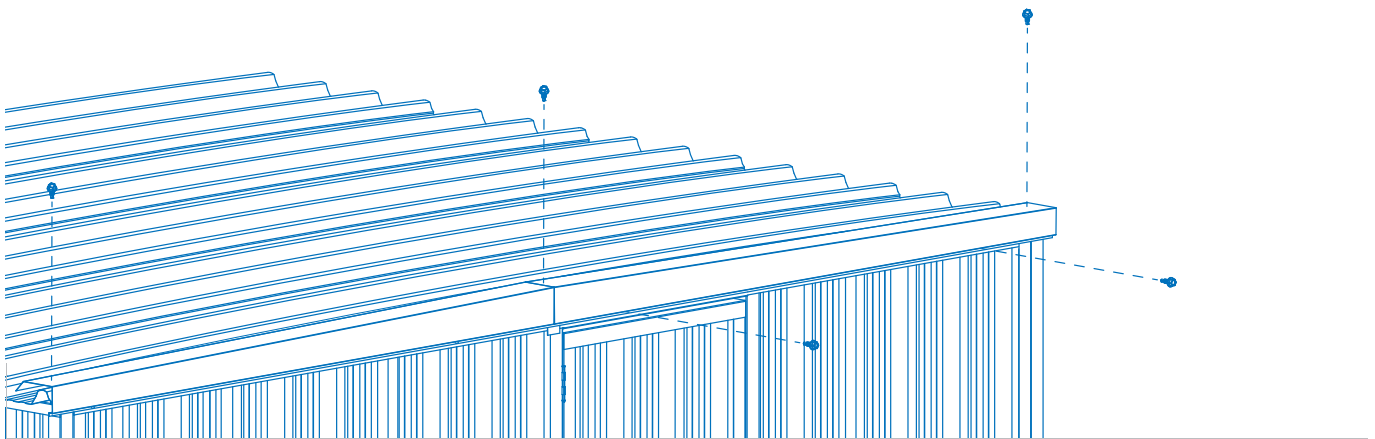

Figure 25

GUTTER OPTION

If you have chosen the gutter option for your Potter the components will include extra items as detailed in the list below. First prepare each of the gutters ready for installation. Select the location of the downpipe and install the downpipe outlet into the one of the gutters. Place the outlet up against the back of the gutter

approximately 40mm from the end and trace around the outlet. Cut out the appropriate sized hole to ensure the outlet fits snugly. Attach the downpipe outlet and stop ends with rivets (Figure 26). Seal around the edge of the downpipe outlet and stop ends with silicone sealant (Figure 27).

- 2 x VF gutters
- 2 x Left gutter stop end
- 2 x Right gutter stop end
- 8 x Universal deck straps
- 2 x Downpipe outlet
- 2 x Downpipe bracket
- 2 x Downpipe

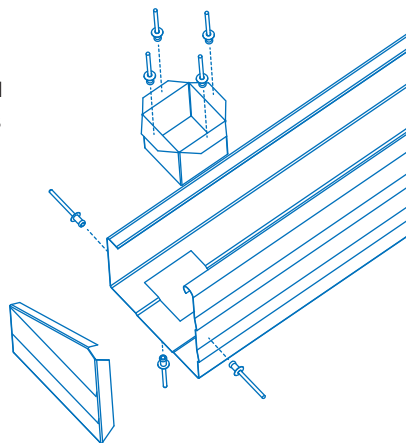

Figure 26

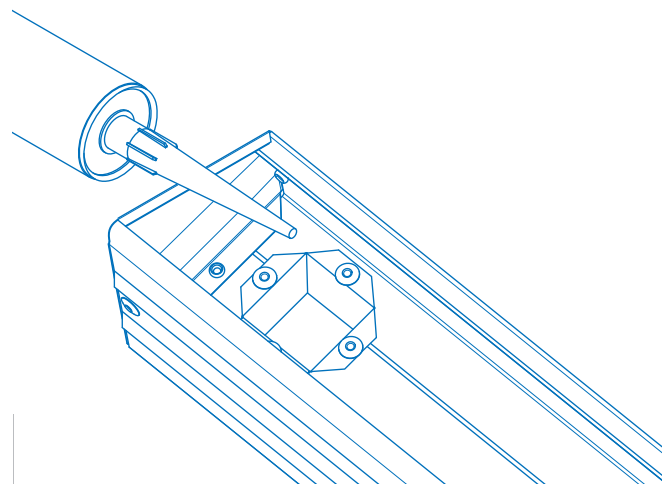

Figure 27



Using tin snips make a pair of cuts 20mm apart, 150mm from the end of the gutter. Bend the tab back over itself (Figure 28). Repeat for the other end and a further two more evenly spaced with a

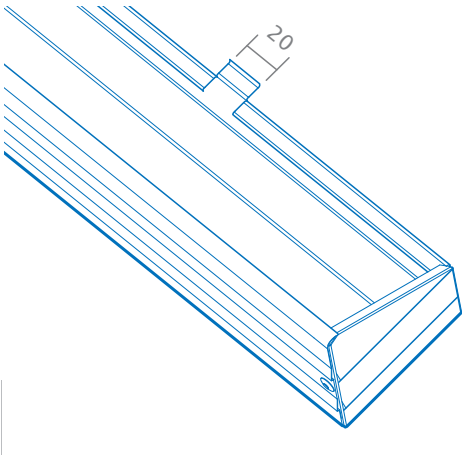

Figure 28

After Step 13 has been completed you can install the gutter brackets. Place the first bracket under the lip of the gutter with the flat end in the middle of the second roof sheet pan in from the edge, attach

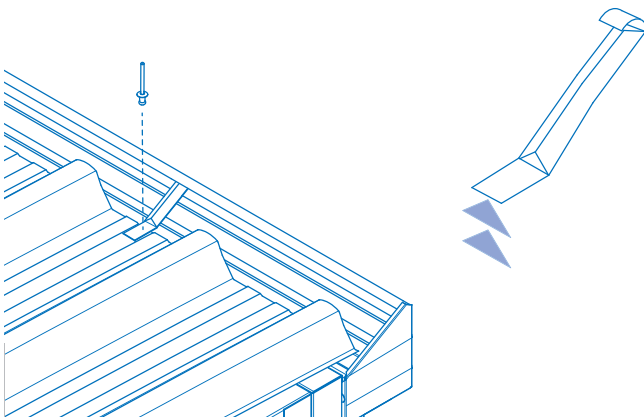

Figure 30

maximum spacing of 1200mm (Figure 29). Attach gutter to top rail with rivets (Figure 29). Repeat for opposite gutter. Return to Step 13.

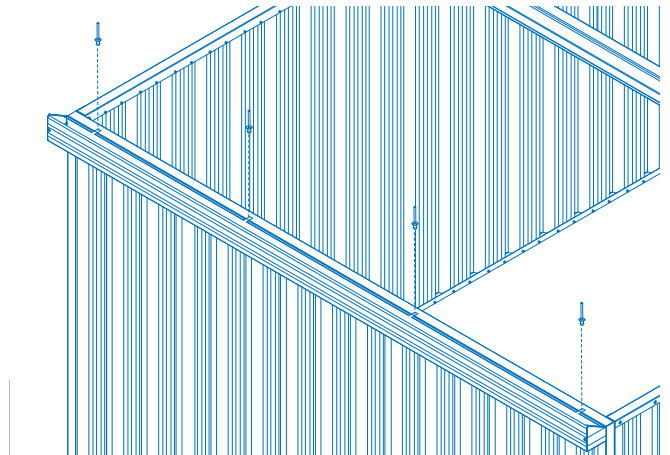

Figure 29

with rivet (Figure 30). Repeat for remaining three bracket placing one in every fourth pan (Figure 31). After both gutters are attached return to Step 14.

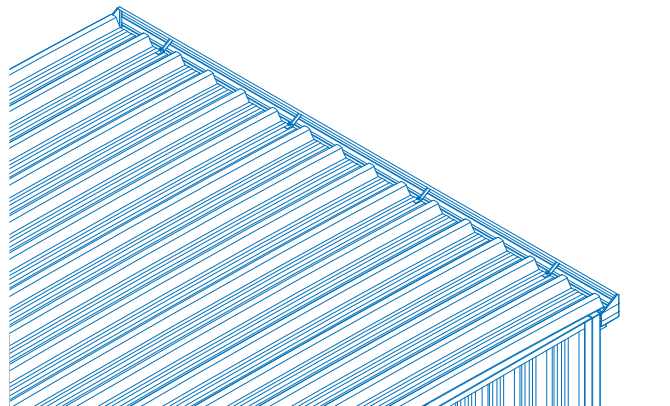

Figure 31

DOWNPIPE OPTION

Cut the downpipes to the required length, allow room for any downpipe shoes or other optional fittings. Place the downpipe over the downpipe outlet and attach with two rivets through both sides of the downpipe (Figure 32). Seal with silicone.

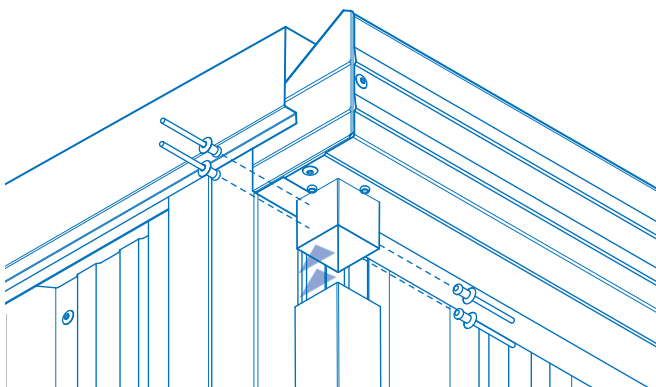

Figure 32

Place the downpipe bracket as close to the ground as possible. Fix the bracket using downpipe rivets (Figure 33). Seal with silicone.

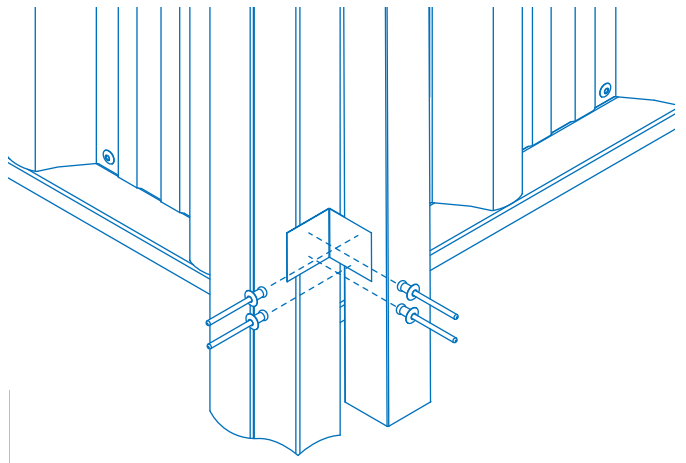

Figure 33

DOUBLE PA DOOR OPTION

If you have chosen the double door option for your Potter there will be one less wall sheet and the Z section door stop will measure 1545mm. Included with the extra P.A. door is a seam flashing. Locate your position for the P.A. doors, the example provided is for a double door hung one sheet from corner post (Figure 34). Note: Do not position centre of double door directly below C-section support beam. The space for the P.A. door can be created by half lapping one sheet over another full sheet. To eliminate cutting sheets it is recommended you temporarily locate both jambs at their

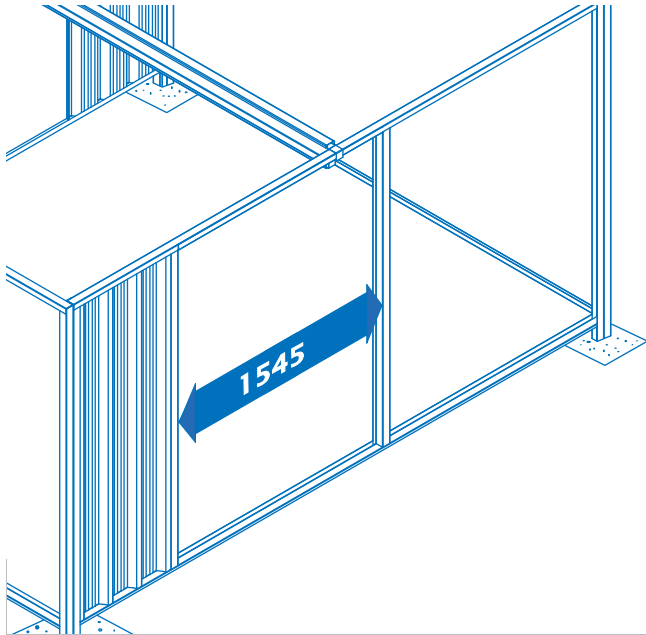

Figure 34

remeasure the door jambs and adjust if necessary (Figure 34). Install the first door jamb using a 10x16 screw attached to the top channel and a rivet attached to bottom Z rail (Figure 15). Before fixing the P.A. door to the jamb decide which of the two doors will open first, the handle will attach to this door. Attach the seam flashing to the other door using four 10x16 screws with a recommended 20mm overhang (Figure 36). Position the door and

10x16 screws at
600mm centres start
100mm from end

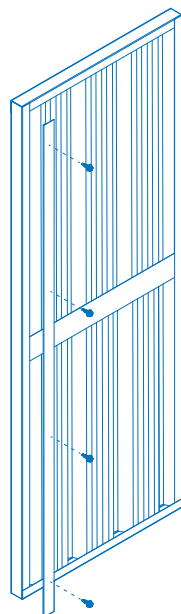
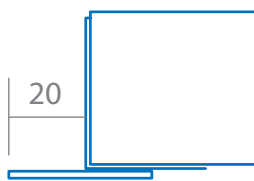

Figure 36

approximate positions. Lay the wall sheets on the ground lining up all sheets with the intended position of the P.A. doors. Proceed to install the wall sheets from the corner post working toward the first door jamb (Figure 35). Refer lapping detail (Figure 42). Secure sheets with one rivet per crest at the top, two rivets per pan at the base and one rivet mid-span at the join between sheets (Figure 11). The Z rail base should be temporarily supported during this step. Repeat procedure working back from opposite corner post.

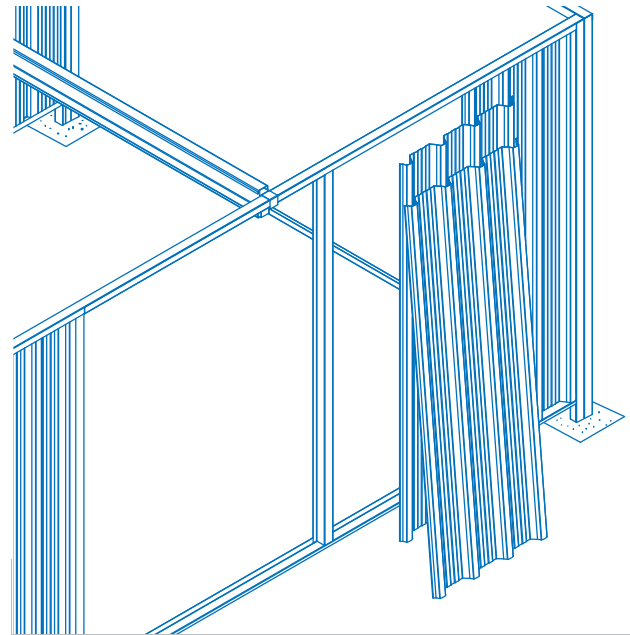

Figure 35

fix to the jamb using four 10x16 wafer head screws per hinge (Figure 16). Close the door and check the position of the unfixed door jamb, before fixing ensure the Z section door stop will fit. Install remaining door jamb (Figure 15). Insert Z section door stop into top channel and attach with two rivets (Figure 14). Position the door and fix to the jamb using four 10x16 wafer head screws per hinge (Figure 37).

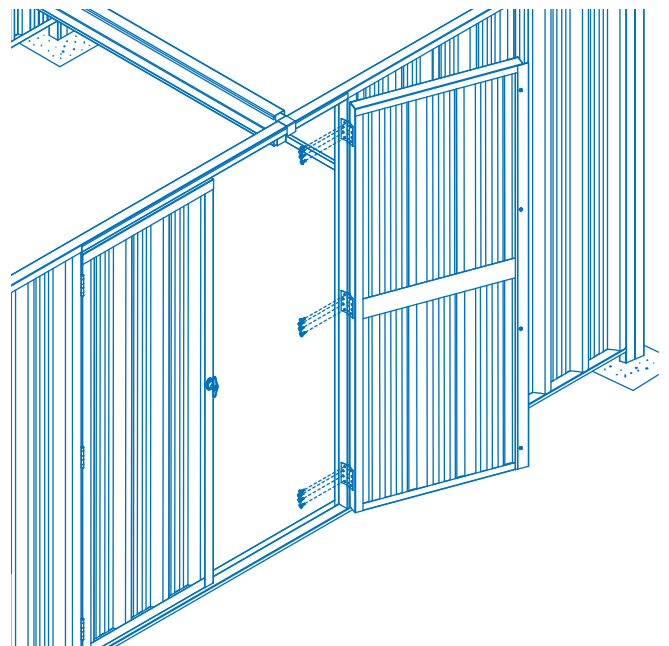

Figure 37



LOUVRED WINDOW OPTION

If you have chosen the louvred window option for your Potter, one of the 2100mm walling sheets will have to be trimmed to length with tin snips. The example provided is for a window one sheet from the corner post on the short side of the shed (Figure 38). Fix one full length wall sheet against the corner post. Then fix the trimmed sheet as previously described (Figure 42). Place the remaining sheets loosely into position and check the window will fit the opening. Ensure the wall sheets either side of the window tightly abutt the frame so no gaps occur. Correct spacing of the

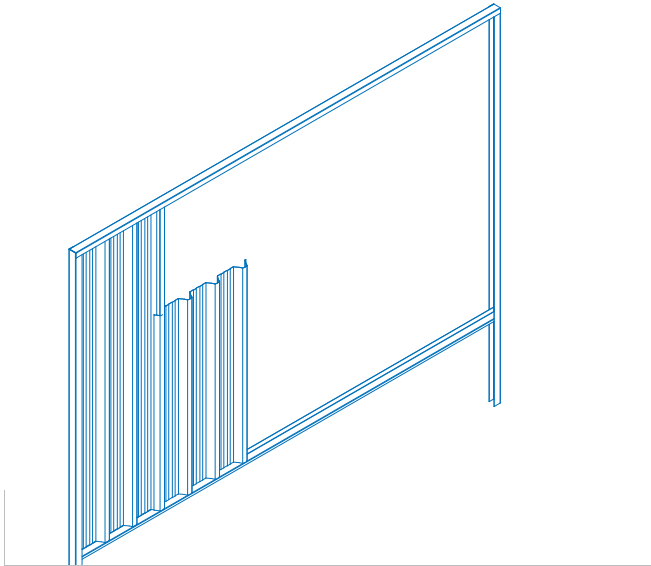

Figure 38

sheets is best achieved by marking the top and bottom tracks and fixing the sheets to these marks. Fix the remaining sheets working back from the corner post (Figure 42). Place the pre-assembled louvred window into the opening and check for squareness. Install with rivets securing the window frame to the crests of the wall sheet and evenly spaced around the remaining frame (Figure 39). Place a bead of silicone in each corner of the window to prevent water entry.

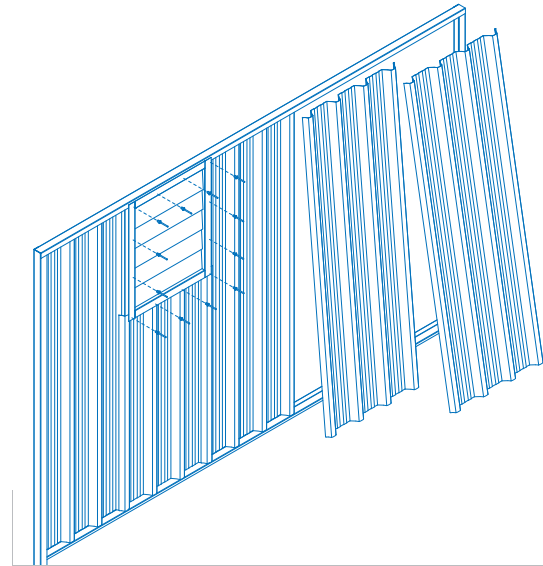

Figure 39

SLIDING WINDOW OPTION

If you have chosen the sliding window option for your Potter, two of the 2100mm walling sheets will have to be trimmed to length with tin snips. The example provided is for a window one sheet from the corner post on the short side of the shed (Figure 40). Note: Do not position the window centrally below the C-section support beam. Fix one full length wall sheet against the corner post. Then fix the two trimmed sheets as previously described (Figure 42). Place the remaining sheets loosely into position and check the window will fit the opening. Ensure that the wall sheets either side of the window

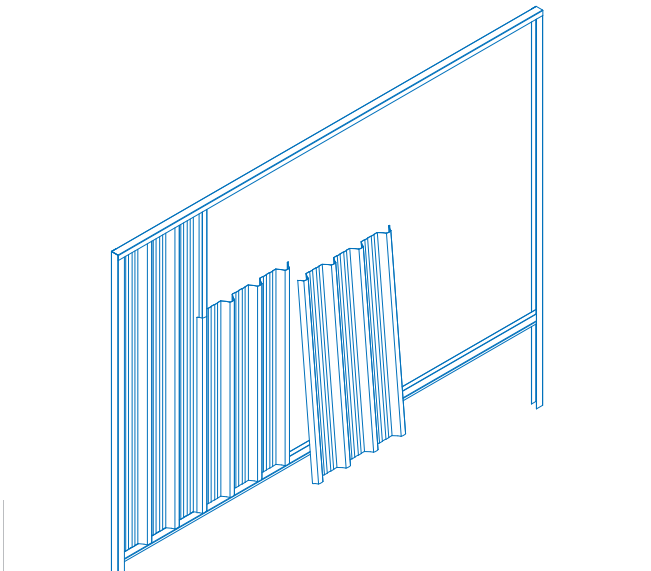

Figure 40

tightly abutt the frame so no gaps occur. Correct spacing of the sheets is best achieved by marking the top and bottom tracks and fixing the sheets to these marks. Fix the remaining sheets working back from the corner post (Figure 42). Place the pre-assembled sliding window into the opening and check for squareness. Install with rivets securing the window frame to the crests of the wall sheet and evenly spaced around the remaining frame (Figure 41). Place a bead of silicone in each corner of the window to prevent water entry.

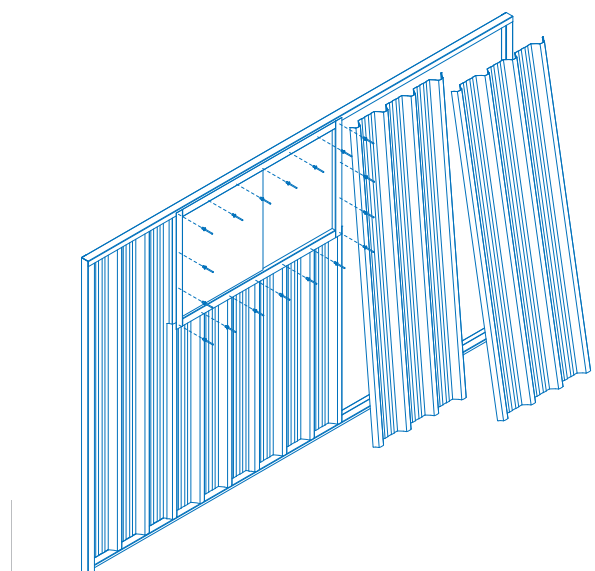

Figure 41

NOTES



QUEENSLAND

- ORMEAU Ph: (07) 3451 4444 1 Mavis Crt
 • CRESTMEAD Ph: 3451 4411 179 Magnesium Dve
 • TOOWOOMBA Ph: 4638 9322 167 Herries St
 • VIRGINIA Ph: 3451 4411 2037 Sandgate Rd
 • CABOOLTURE Ph: 5431 4100 17 Concorde Pl
 • MAROOCHYDORE Ph: 5351 0100 14 Pike St, Kunda Park
 • GOLD COAST Ph: 3451 4411 108 Eastlake St, Carrara
 • CAPALABA Ph: 3451 4411 Cnr. Smith St & Redland Bay Rd
 • ARCHERFIELD Ph: 3451 4411 Cnr. Beaudesert & Granard Rd
 • REDBANK PLAINS Ph: 3451 4411 326 Kruger Pde

NEW SOUTH WALES

- HUNTINGWOOD Ph: (02) 8811 7211 15 Liberty Rd
 • CAMPBELLTOWN Ph: 8811 7211 22 Blaxland Rd
 • PENRITH Ph: 8811 7211 125 Coreen Ave
 • NEWCASTLE Ph: 4922 2777 2 Hartley Dve, Thornton

AUSTRALIAN CAPITAL TERRITORY

- FYSHWICK Ph: (02) 6280 5905 25 Tennant St

VICTORIA

- EPPING Ph: (03) 9409 9260 17 Scanlon Dr
 • DEER PARK Ph: 9409 9260 1027 Western Hwy
 • KILSYTH Ph: 9409 9260 73 Canterbury Rd
 • DANDENONG Ph: 9409 9260 14 Princes Hwy, Doveton

SOUTH AUSTRALIA

- GEPPS CROSS Ph: (08) 8349 5559 125 Cavan Rd
 • RICHMOND Ph: 8349 5559 221 Marion Rd, Marleston
 • LONSDALE Ph: 8349 5559 Cnr. Dyson & O'Sullivan Beach Rd
 • ST AGNES Ph: 8349 5559 129 Tolley Rd
 • GAWLER Ph: 8522 1132 16 Main North Rd, Willaston
 • GOOLWA Ph: 8555 2825 29 Hutchinson St
 • VICTOR HARBOR Ph: 8552 5164 95 Victoria St
 • MURRAY BRIDGE Ph: 8531 9191 15 Hindmarsh Rd
 • KADINA Ph: 8828 1555 9 Kennett St
 • RIVERLAND Ph: 8582 4666 53 Zante Rd, Berri
 • PORT AUGUSTA Ph: 8642 6333 70 Victoria Pde
 • WHYALLA Ph: 8645 7344 50 Ian St, Whyalla Norrie

WESTERN AUSTRALIA

- CANNING VALE Ph: (08) 9455 5111
 Corner of Bannister Road and Hopewell Street
 • MALAGA Ph: 9455 5111 Cnr. Marshall Rd & Energy St
 • BALCATT A Ph: 9455 5111 140 Balcatta Rd
 • MANDURAH Ph: 9455 5111 11 Fitzgerald Rd
 • BUNBURY Ph: 9791 4200 Cnr. Strickland St & Zaknic Pl
 • BUSSELTON Ph: 9752 3122 18 Wright St
 • KALGOORLIE Ph: 9080 8080 8 Federal Rd
 • BROOME Ph: 9191 3800 26 Hunter St

NORTHERN TERRITORY

- BERRIMAH Ph: (08) 8944 2300 780 Stuart Hwy
 • ALICE SPRINGS Ph: 8950 9898 6 Ghan Rd

NEW ZEALAND

- CHRISTCHURCH Ph: (03) 338 9063 55 Hands Rd
 AUCKLAND Ph: (09) 274 6487
 Block 4, 22 Harris Rd, East Tamaki

BROCKPOI

© Copyright March 11

All brands and logos/images accompanied by ® or ™ are trade marks of Stratco (Australia) Pty Limited.

www.stratco.com.au

WALL SHEETS

Fix top channel to crest

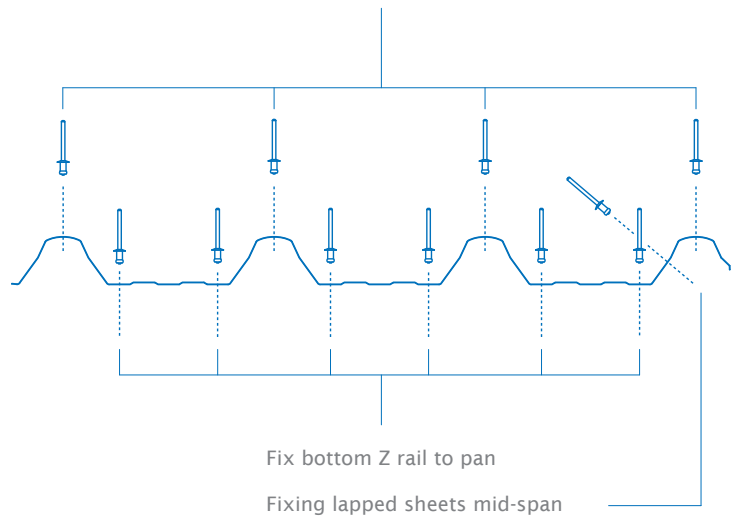

ROOF SHEETS

Screw adjacent overlapping rib

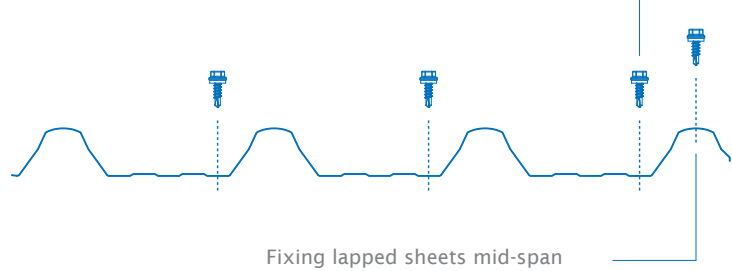

LAPPING DETAIL



HALF LAPPING DETAIL



Figure 42

MAINTENANCE

Your Stratco Flat Roof Homeshed will maintain its good looks for even longer with a simple wash and wipe down. Cleaning should be performed as often as is required to remove any dirt, salt and pollutants.

Stratco Homesheds are produced from the highest quality materials and will provide many years of service, refer to the 'Selection Use and Maintenance' brochure for more information on how to get the best out of your product.