

# Gutters & Downpipes

## YOUR COMPLETE GUIDE TO INSTALLING STRATCO GUTTERS AND DOWNPIPES.

Stratco Gutters and Downpipes are both fashionable and functional accessories, that enhance the look of your home and minimise the risk from water damage. Stratco offer a range of quality gutter and downpipe products and all the advice and tools you need to do a competent job for yourself. Do not underestimate the damage poor gutters and downpipes cause, take these handy tips and replace them now. For information on installing High Fronted Gutters please refer to the Stratco 'High Fronted Gutters Information Guide' on the Stratco website.

### TOPICS COVERED INCLUDE

- BEFORE YOU START
- TOOLS REQUIRED
- GUTTER STYLES
- COMPONENTS & ACCESSORIES
- INSTALLATION
- REMINDERS

### BEFORE YOU START

When your material has arrived on site, check each piece against the cartnote supplied. Carefully read this leaflet to ensure that you are familiar with all the steps involved. Ensure you have adequate tools for the job.

### TOOLS REQUIRED



• HACKSAW

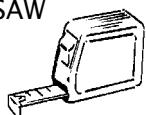

• TAPE MEASURE



• TIN SNIPS



• RIVET GUN

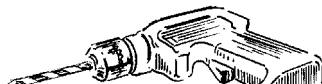

• DRILL / DRILL BITS

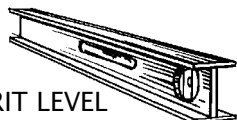

• SPIRIT LEVEL

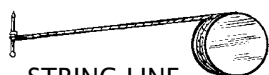

• STRING LINE

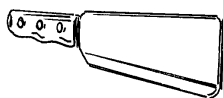

• HACKING KNIFE



• HAMMER



• SILICONE



• WALKING PLANKS



• RIVETS 1/8"X1/8"



• 30mm GALV. CLOUTS

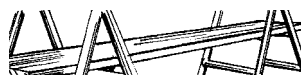

• LADDERS & SCAFFOLD

### GUTTERS

Stratco has designed an extensive choice of gutter styles, from the more traditional colonial styles to today's modern contemporary designs. Most of Stratco's gutters have the revolutionary suspension rib. This enables the gutter if used with either Clickfast®, or Clickform™ steel fascia, to be fixed with the Stratco Suspension Clip, the system which has proudly received an Australian Classic Design Award. When using timber fascia the suspension rib can be used with timber fix clips.

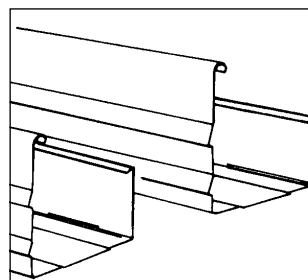

• VFC AND VC SQUARE FASCIA GUTTER

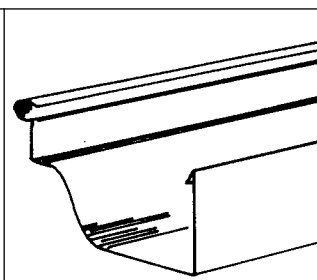

• OG GUTTER

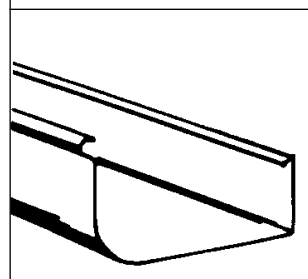

• 125D (QUAD) GUTTER

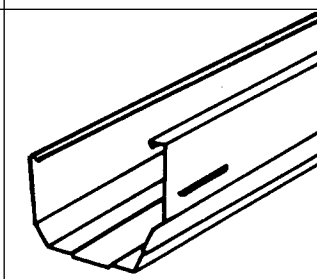

• CLICKFORM EAVES GUTTER

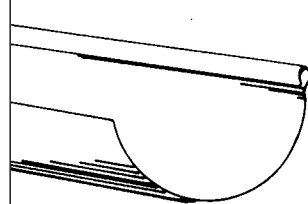



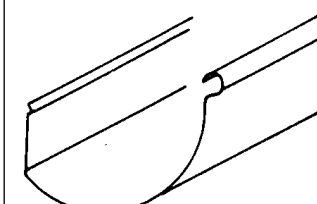

• 150 HALF ROUND GUTTER

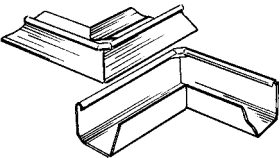
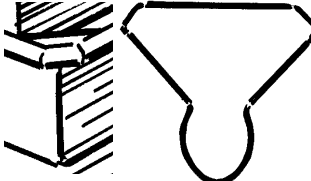
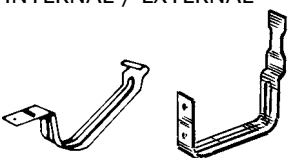
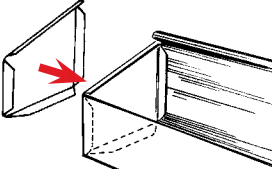
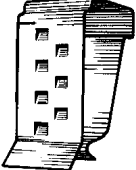

• 150 SMOOTHLINE GUTTER

Note: Many gutters are available slotted to prevent overflow water from entering the eaves. Check with your local Stratco office to confirm if this is available in your gutter profile.

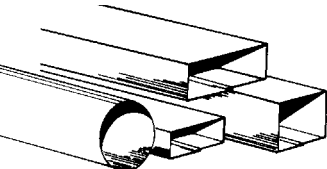
# ACCESSORIES

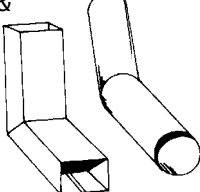
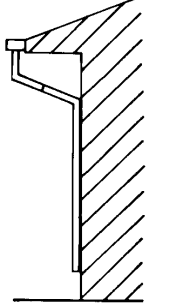
<p><b>MITRES</b> INTERNAL/EXTERNAL</p> 	<p><b>MITRE GUSSETS</b></p> 
<p><b>GUTTER STRAPS:</b> INTERNAL / EXTERNAL</p> 	<p><b>STOP ENDS</b></p> 
<p><b>SUSPENSION CLIPS</b></p> 	<p><b>P CLIPS</b></p> 
<p><b>DOWNPIPES</b></p> 	<p><b>GUTTER OUTLETS</b></p> 
<p><b>ELBOWS &amp; SHOES</b></p> 	<p><b>DOWNPIPE OFFSETS</b></p> 

## PRE-ASSEMBLE MITRES, STOP ENDS AND OUTLETS.

Determine method of supporting and strengthening gutter on the fascia. Gutter support can include external brackets, or internal straps used in conjunction with either P-clips, timber scotia or suspension clips.

- 1: Cut required length with hacksaw and tinsnips.
- 2: Fit stop ends where required.
- 3: Cut holes (outlets) for gutters with a hacking knife, and rivet outlet into position.
- 4: Cut mitres where needed. Pre-made mitres are available. See the section on making mitres if you wish to make your own.
- 5: Remove all swarf and debris from inside of gutters. If gutters are pre-coloured steel remove plastic from outside of gutters prior to installation.
- 6: Seal internally all stop ends, gutter outlets and mitres with silicone sealant.
- 7: Make downpipe offsets. Pre-made downpipe offsets are available, however see section on making offsets if you wish to make your own.

## INSTALLATION OF BRACKETS

### EXTERNAL BRACKETS

Nail External brackets at 1.2 metre centres, following string line. Once all brackets have been installed, place gutters into external brackets. Bend tag over bead to hold in place

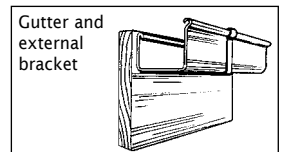

### P - CLIPS

Install P-clips if required using the same method as external brackets. Once P-clips have been installed, sit gutters onto P-clip lip then bend small tag of P-clip over back of gutter to hold the gutter into position.

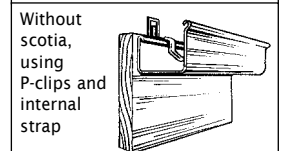

### INTERNAL STRAPS

Install internal straps at 1.2 metre centres to hold face of gutter into position. Install pre-made mitres into corners. Internal straps can also be used in conjunction with gutter suspended on timber scotia nailed to a timber fascia.

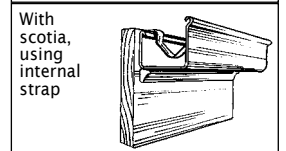

### SUSPENSION CLIPS

This can be used on steel & timber Fascia with Internal Straps. No string line is required. For timber fascia nail your timber suspension clip into place by placing a clout into the allocated hole in the top of the clip and driving the clout into the top of the timber fascia, holding the clip into position. Clips are to be placed at maximum of 1.2m centres. Steel fascia suspension clips are rolled over the top of steel fascia and placed into position at 1.2 m centres. (See section on steel fascia).

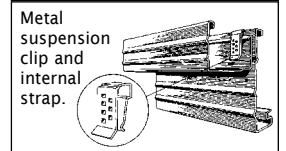
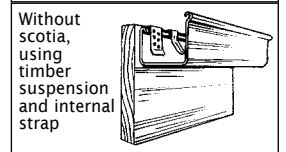

## PRE-INSTALLATION

### MEASURING

Measure length of fascia, allowing enough for mitres and any joints that may be required. Generally, external corners will require at least twice the width of the gutter to be sacrificed making the mitre, but internal corners require no extra material. Joins should overlap approx 100mm. If installing pre-made stop ends no extra length is required, but "return" stop ends require the width of the gutter to be added for each stop end.

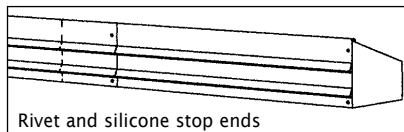

### DETERMINE GUTTER SUPPORT

There are 4 basic methods of supporting a gutter.

- A: External brackets.
- B: Internal straps and P clips.
- C: Internal straps and scotia.
- D: Suspension clips and internal straps.

### DETERMINE GUTTER FALLS

- 1: Using a string line, nail one end to the fascia, running string line from corner to corner, making sure the string line is taut.
- 2: The fall of the gutter should be calculated (correct fall is 1:500). Check the fall with a spirit level. The fall must run towards the gutter outlet.

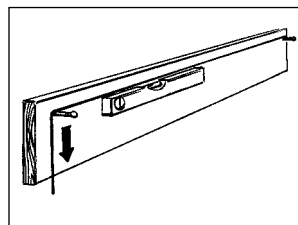

## INSTALLATION OF GUTTER

1: Ensure all gutter outlets and stop ends are fitted at the correct locations prior to installation of the gutter.

2: Place gutter on P-clips or scotia already installed and hold into place by driving a galvanised nail into the fascia just above the back of the gutter. Bend the nail down to hold the gutter but allow expansion and contraction.

3: To install the next length of gutter, determine the fall of the gutter. Joins should always be overlapped to allow water to flow "over" the joint instead of "into" the joint. Open the bead of the "outside" gutter with a pair of pliers, and close up the bead of the "inside" gutter.

4: Slide the upstream gutter (inside) into the downstream gutter (outside) allowing a 100mm lap. Rivet and silicone the two gutters together, ensuring that all metal filings (swarf) are first cleaned from the gutter. Silicone should be smoothed to ensure that the passage of water is not impeded.

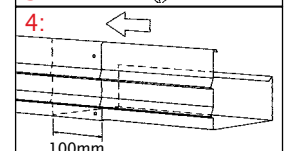
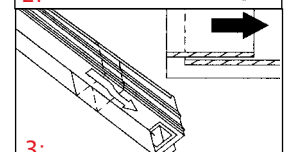
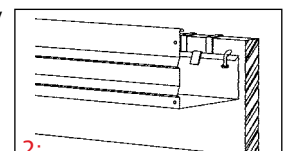

## GUTTER INSTALLATION CONTINUED

- 5: Fit pre-made gutter mitres as required.
- 6: Roll internal straps into the bead of the gutter if being used and fasten to the top of the fascia. Use the gutter strap to ensure the bead remains parallel to the fascia.
- 7: Fit downpipe, downpipe accessories and straps.

## INSTALLATION OF GUTTERS USING SUSPENSION CLIPS

Gutter is pulled upwards until the suspension clip engages into the suspension rib of gutter. Place internal gutter strap into position. The fall of the gutter is obtained by a series of teeth placed on the suspension clip. The highest end of the gutter should be in the top tooth. The lowest end in the second to bottom (minimum 1 : 500 fall required).

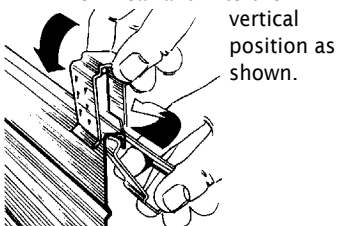
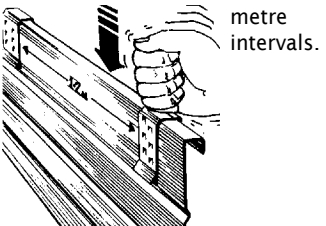
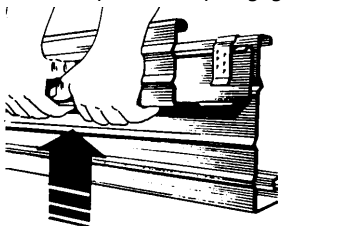
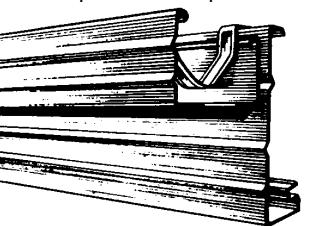
<p><b>1 ROLL IN CLIPS.</b> Push suspension clip up from rear and into the vertical position as shown.</p> 	<p><b>2 CLIP SPACING</b> Knock suspension clip down with fist. Place at 1.2 metre intervals.</p> 
<p><b>3 INSTALL GUTTER</b> Pull gutter upwards until suspension clip engages.</p> 	<p><b>4 FIX INTERNAL STRAPS</b> Roll gutter strap into bead &amp; press over top of fascia.</p> 

## FIXING DOWNPIPE TO GUTTER

- 1: Measure the distance between the bottom of the gutter to the ground level (leave enough to fit a shoe or PVC fitting).
- 2: Slide the small end of one downpipe (marked by a cut V or dot one end) into the big end of the other. Rivet the downpipe at the back as not to show the rivet head, then use a hacksaw to cut to the desired length.
- 3: Fit the downpipe to the existing outlet using rivets, then using downpipe straps, fix against wall or post using screws or masonry nails.

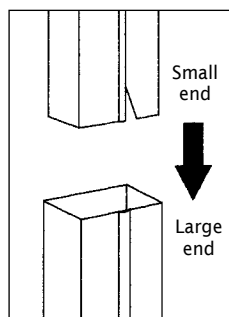

## MAKING 'RETURN' STOP ENDS

- 1: Determine if the end is to be left or right.
- 2: Mark a line completely around the outside of the gutter at a distance from the end, equal to the width of the gutter.
- 3: Mark a tag-line parallel to the first approximately 10mm toward the end of the gutter, across the back and the base of the gutter.
- 4: Cut the back and the base from the gutter leaving the 10mm tags in place. Fold these up at 90 degrees.
- 5: Cut a 45° notch in the bead of the gutter at the marked line, and fold the face of the gutter to form the end.
- 6: Rivet and silicone.

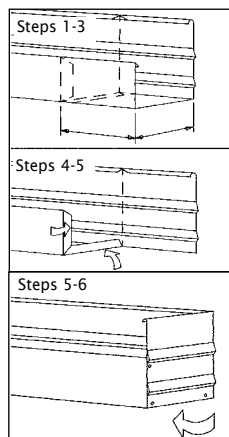

## DOWNPIPE OFFSETS

When installing downpipes, sometimes the eaves overhang will require the use of a downpipe offset. There are two ways of producing a downpipe offset.

1: Stratco produce a complete downpipe offset, which is suitable for your nominated eaves dimension. This has a slip joint to make it adjustable for small variances in eaves sizes, which may vary on your home.

2: Elbows and shoes can also be pre-made and then riveted onto your downpipe length producing your own downpipe offset. Alternately, one piece downpipe offsets can be made on the site.

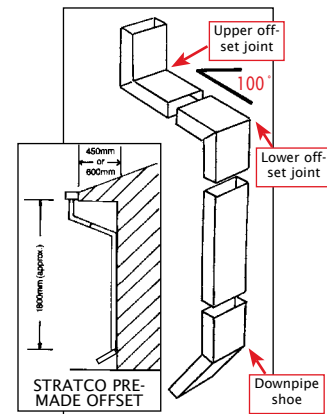

## MAKING A DOWNPIPE OFFSET

### CREATING THE "LOWER OFFSET" JOINT.

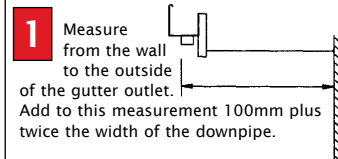
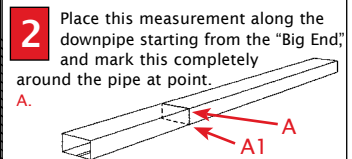
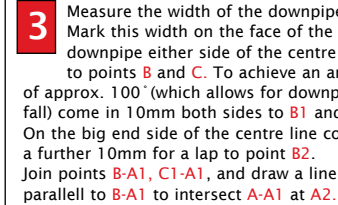
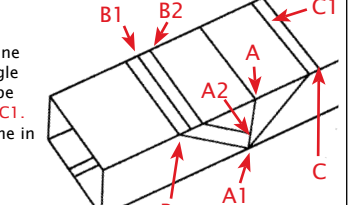
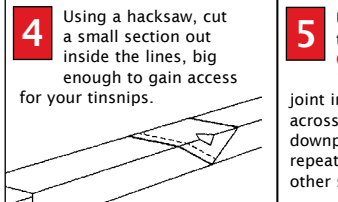
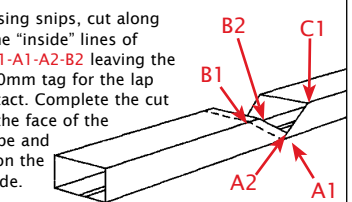
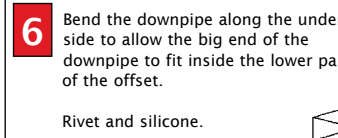
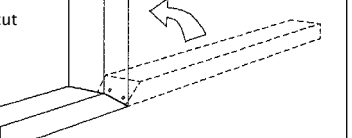
<p><b>1</b> Measure from the wall to the outside of the gutter outlet. Add to this measurement 100mm plus twice the width of the downpipe.</p> 	<p><b>2</b> Place this measurement along the downpipe starting from the "Big End," and mark this completely around the pipe at point A.</p> 
<p><b>3</b> Measure the width of the downpipe. Mark this width on the face of the downpipe either side of the centre line to points B and C. To achieve an angle of approx. 100° (which allows for downpipe fall) come in 10mm both sides to B1 and C1. On the big end side of the centre line come in a further 10mm for a lap to point B2. Join points B-A1, C1-A1, and draw a line parallel to B-A1 to intersect A-A1 at A2.</p> 	
<p><b>4</b> Using a hacksaw, cut a small section out inside the lines, big enough to gain access for your tinsnips.</p> 	<p><b>5</b> Using snips, cut along the "inside" lines of C1-A1-A2-B2 leaving the 10mm tag for the lap joint intact. Complete the cut across the face of the downpipe and repeat on the other side.</p> 
<p><b>6</b> Bend the downpipe along the undercut side to allow the big end of the downpipe to fit inside the lower part of the offset. Rivet and silicone.</p> 	

### CREATING THE "UPPER OFFSET" JOINT

- 1 Place completed "Lower Offset" joint against the wall with the large end of downpipe towards the gutter outlet.
  - Using a plumb line mark from the outside of the gutter outlet, completely down the side of downpipe. This point becomes the centre point of the cut of the upper offset joint, to be marked out. Cut and seal as per steps 3 to 6 above. It is important to note that for the "Upper Offset" the opposite face of the downpipe is used so the seam is cut.
  - Before riveting the top of the offset joint completely, check to make sure the top of the offset joint is parallel to the bottom part of the downpipe offset.

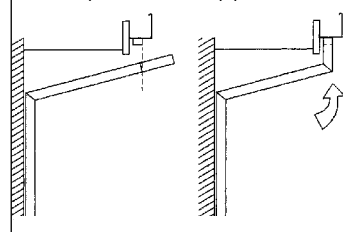

### CREATING THE "SHOE"

- 1 Using a second length of downpipe, measure in from the "small" end of the downpipe, the length required to bring the downpipe into the stormwater pipe, allowing for a slip joint, and mark this distance completely around the pipe using a square.
  - To create a 45 degree angle, mark a distance equal to half the width of the downpipe on either side of this centre line on the face of the downpipe.
  - Mark out, cut and seal as per steps 3 - 6 above.
  - Slide the upper and lower offsets together to form the final finished offset.

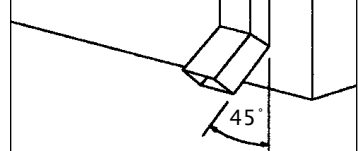

# TO MAKE A GUTTER MITRE

- 1** Measure fascia from the corner of the fascia to existing gutter allowing 100mm for gutter lap.

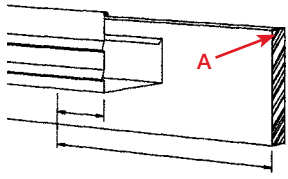

- 2** Place length of gutter upside down on the ground so that the base of the gutter is facing you.

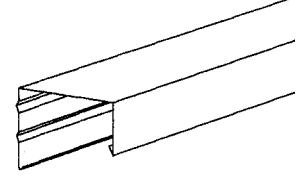

- 3** Mark where the fascia corner will occur (point A) on the back of gutter, and using a 90° square and pencil, draw a line across the outside of the back of gutter.

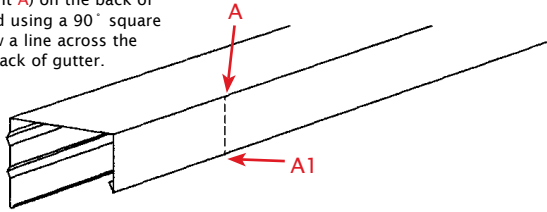

- 4** On the back of the gutter place a further 2 marks, each equal to the width of the gutter (at points B and C) to extend beyond the fascia corner. The central mark B should be extended completely around the outside of the gutter using the 90° square and pencil.

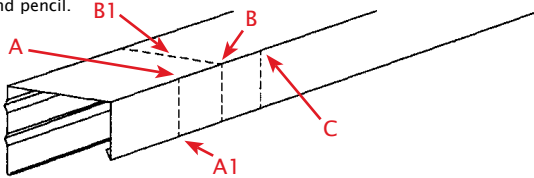

- 5** On the base of gutter, draw a line to connect the continuous line from B1 to both A and C. Mark a line 10mm away from, but parallel to A-B1, and extend this across the back of the gutter. This will produce a "lap" when the gutter mitre is formed. This parallel line should also extend up the back of the gutter to A1.

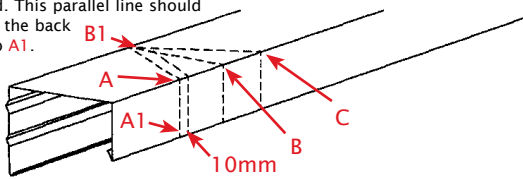

## REMEMBER TO

- Waterproof each rivet with silicone sealant applied on the "weather" side.
- The minimum fall of guttering to the downpipe end is 1 in 500 (or 12mm every 6m).

- 6** Using tinsnips, cut along the line on one side and on the other side, cut on the parallel line which is 10mm in from the original line drawn connecting A-B1. You will cut out the complete V marked into the gutter. In addition, remove excess material at A and B1 to allow the outside of the gutter to fold easily, and the tags to overlap.

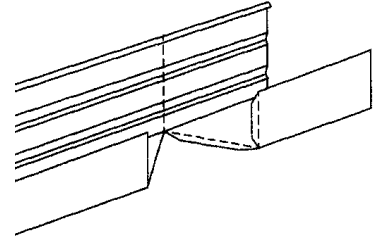

- 7** For a square gutter cut a 45° notch into the bead of the gutter using a hacksaw and tin snips at B1 directly in line with the point of the V on the base of the gutter. For gutters with an external bead, such as quad (D) or OG, a single hacksaw cut is used to cut the bead. A mitre gusset must then be attached to complete the bead line.

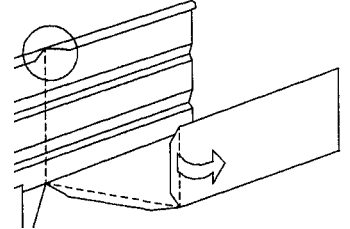

- 8** Fold the gutter around until the back sections touch each other. Fold tag inside the back gutter. Rivet and silicone. You have produced an external gutter mitre. To produce an internal gutter mitre, reverse your V line marks on the gutter so that point B1 is exchanged for point B and the face of the gutter is cut out not the back. Then follow the above steps. With some gutters a mitre gusset will be required to cover any gap in the gutter bead.

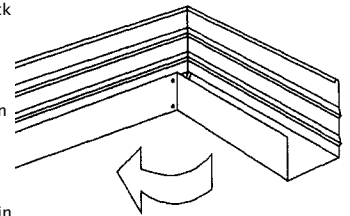

## COMPLY WITH REGULATIONS

All building work must be carried out in accordance with the Building Code of Australia (BCA). This code refers to various Australian Standards, which provides acceptable standards of product manufacture and building practice. These include:

- AS/NZ 3500.3 Plumbing and Drainage, Stormwater Drainage
- AS/NZS 3500.5 National Plumbing and Drainage, Domestic Installations

Prospective users of Stratco materials should first ensure that they understand these requirements and any other state or territory specific regulations that may apply. In some states of Australia (eg. NSW and Victoria) work involving the installation of roofing, rainwater goods and drainage may need to be installed by a suitably qualified tradesperson, and comply with statutory warranties. (Refer [www.deus.nsw.gov.au/water/plumbing.asp](http://www.deus.nsw.gov.au/water/plumbing.asp))

Care should also be taken in the design and installation of roof drainage systems given the wide range of factors such as rainfall intensity, gutter capacity and selection, number and placement of downpipes and sumps. Care should also be taken to select the most suitable gutter style. Gutters that have a front higher than the back are popular to hide the exposed ends of roofing, but unless manufactured with optional slots or fixed with the bead lower than the top of the fascia may contravene building regulations. Other fixing options can be used to eliminate overflow from the back of a gutter into a building. These include additional overflow weirs placed either in the gutter or stop end, rainheads with overflow weirs, custom back flashings, leaving a gap between the fascia and gutter back, or other proprietary systems or trade solutions.

Up to date information about Stratco products, spans, installation requirements and technical advice can be found on our website at [www.stratco.com.au](http://www.stratco.com.au) and it is advisable to obtain current information prior to ordering any materials. If additional information is required contact the Stratco office in your state.



CONTACT

**1300 165 165**  
**www.stratco.com.au**

All brands and logos/images accompanied by ® or ™ are trade marks of Stratco (Australia) Pty Limited.