

MAXICLAD

THE PRODUCT

Maxiclad is an extremely versatile wall cladding material suitable for a variety of applications. It is particularly suitable for fencing, walling, screens, fascias, ceilings, gables, garages, sheds, aviaries and caravan applications. Its low 12mm rib height has proven to be popular with architects consumers and tradesmen as it produces a neat clean finish. The wide 815 mm coverage makes Maxiclad an attractive product to use as less sheets are needed to cover the chosen area.

Maxiclad is an economical product to use as its wider sheets mean quicker fixing which results in savings in labour time and is less expensive per metre than products like corrugated iron.

LENGTHS

Maxiclad is rolled to lengths that suit your specific requirements. Maximum lengths available are 1.2 metres. Sheeting longer than 10 metres requires special transport, handling facilities and on site labour to assist in unloading these sheets.

SUITABILITY

Stratco Maxiclad is recommended for walling applications as its low rib height does not make it suitable for roofing applications where weather proofing is essential.

ACCESSORIES

Coloured caps for type 17 screws and tek screws to match the range of colour finishes are available as well as touch up paint for unplanned mishaps that may occur during installation.

DESIGN INFORMATION

Span tables have been determined based on the following conditions:-

1. Non cyclonic areas.
2. Terrain category two and three.
3. Buildings up to ten metres high and up to 30 metre spans.
4. Maximum internal pressure coefficient +0.2.*
5. Please refer to your nearest Stratco sales office if conditions 1 to 4 do not apply.

ALLOWABLE SPANS -Walling Applications

BUILDING HEIGHT <small>(From ground level to top of cladding)</small>	LOCATION	WIND SPEED M/S	WIND CATEGORY 3			WIND CATEGORY 2		
			INTERNAL SPAN	END SPAN	OVER-HANG	INTERNAL SPAN	END SPAN	OVER-HANG
0 to 3 metres	Canberra	38	1950	1810	410	1410	1310	290
	Melbourne	39	1950	1810	410	1410	1310	290
	Perth	40	1950	1810	410	1410	1310	290
	Hobart	41	1860	1720	370	1340	1240	260
	Adelaide	42	1860	1720	370	1340	1240	260
	Sydney	45	1740	1610	360	1260	1170	260
	Brisbane	50	1570	1460	330	1130	1050	230
3 to 5 metres	Canberra	38	1950	1810	410	1370	1270	280
	Melbourne	39	1950	1810	410	1370	1270	280
	Perth	40	1950	1810	410	1370	1270	280
	Hobart	41	1860	1720	370	1300	1200	260
	Adelaide	42	1860	1720	370	1300	1200	260
	Sydney	45	1740	1610	360	1210	1120	250
	Brisbane	50	1570	1460	330	1090	1010	220
5 to 10 metres	Canberra	38	1820	1690	380	1270	1180	260
	Melbourne	39	1820	1690	380	1270	1180	260
	Perth	40	1820	1690	380	1270	1180	260
	Hobart	41	1740	1610	340	1210	1120	240
	Adelaide	42	1740	1610	340	1210	1120	240
	Sydney	45	1620	1500	340	1130	1050	230
	Brisbane	50	1450	1340	300	1010	940	210

*NOTE: Spans are based on 0.4mm material, for other materials please contact your nearest Stratco sales office for spanning abilities.

MANY COLOUR OPTIONS

Stratco's Maxiclad is available in Zinalume finish. In addition a full range of colour finishes are also available to suit any building design. Maxiclad can be rolled with the colour surface either on the top or underside. Please nominate the side you require when ordering.

MAXICLAD PROFILE

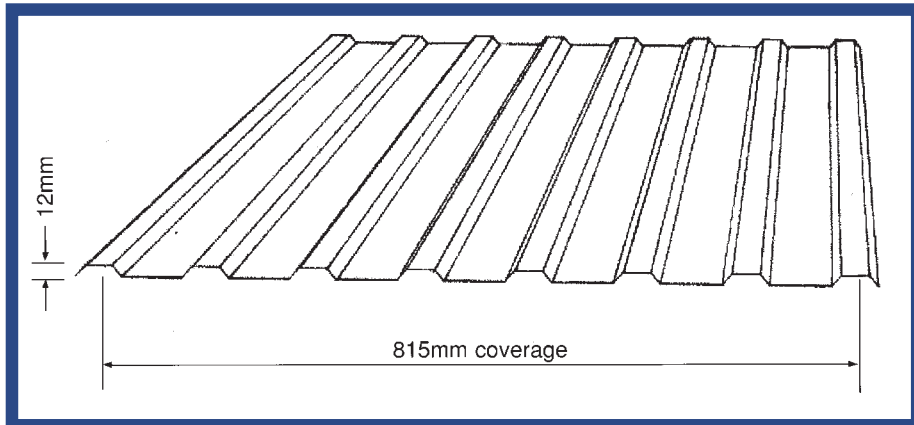

Tolerances: Length \pm 5mm
Width \pm 2mm

SPECIFICATIONS

MATERIAL	TOTAL COATED MATERIAL THICKNESS		APPROX. WEIGHT PER LIN. METRE	APPROX. WEIGHT M ² PER TONNE
Zincalume	0.4mm	G550 Tensile strength AZ 150 coating.	2.5 kgs	372
Colour (All colours)	0.485mm	G550 Tensile strength colour finish over coated steel.	3.3kgs	288
Colour (Weathered Copper Bronze Olive and Beige only)	0.4mm	G550 Tensile strength colour finish over coated steel.	2.5 kgs	372



FIXING RECOMMENDATIONS

LAYING PROCEDURE

Sheets should be laid into the prevailing weather as shown to reduce the possibility of penetration of wind driven rain.

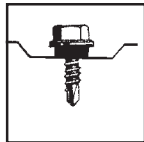
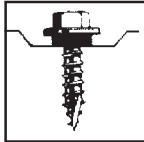
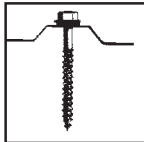

WALLING APPLICATION -Non cyclonic areas

	Steel	Timber
Pan Fixing (one fixing required per pan - fasten adjacent to overlapping rib)	 <p>10 x 16mm tek screw with neoprene washer</p>	 <p>12 x 25mm type 17 tek screw with neoprene washer</p>
Crest Fixing (One fixing required per crest)	 <p>12 x 35mm tek screw with neoprene washer</p>	 <p>12 x 50mm type 17 screw with neoprene washer</p>

ALL TECHNICAL DATA AND INFORMATION IS CORRECT AT TIME OF PUBLICATION. STRATCO METAL RESERVE THE RIGHT TO ALTER DIMENSIONS, TOLERANCES ETC. WITHOUT NOTICE.
Copyright Stratco 1989.