

How To.

ASSEMBLY GUIDE

Boltless 5 Shelf Unit



SS-10489

Please carefully read and follow these instructions to assemble your unit.

ENSURE PROTECTIVE EYEWEAR AND GLOVES ARE WORN WHEN ASSEMBLING THIS UNIT.

WARNING: SERIOUS INJURY CAN BE CAUSED BY TOPPLING FURNITURE. To help prevent tip-over, we recommend you anchor this product to a wall or other suitable surface. Check anchors regularly.

Components

TOOLS REQUIRED: Rubber Mallet, Flat Head Screwdriver, Gloves

① x 10

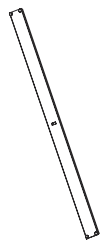

LONG BEAM

② x 10



SHORT BEAM

③ x 8



POST

④ x 5

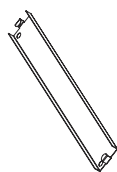

BRACE

⑤ x 5



WOOD BOARD
SHELF

⑥ x 8

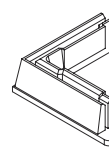

POST CAP

⑦ x 4

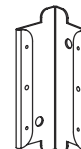

COUPLER

⑧ x 2



ANTI-TIP KIT

Step 1

TIP: Please place all parts neatly in an easy-to-reach place before installation.

Add the feet (6) to the base of the vertical post (3).

Post are directional.

The slot must point down.

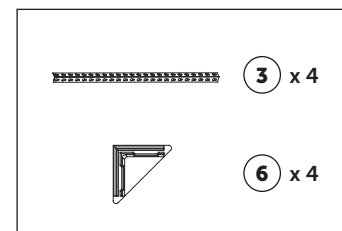
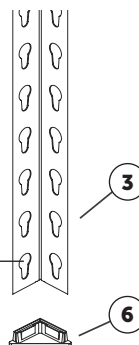

Step 2

Connect one short beam (2) to the bottom of two vertical post (3) leaving one key hole slot at the bottom. Connect one long beam (1) to the vertical post (3) in-line with the short beam (2) which was previously assembled. Ensure both rivets of the beams are inserted in two positions of the vertical beams.

Use a rubber mallet (not included) to secure the connections. Repeat for the two remaining sides.

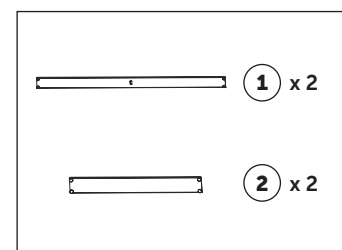
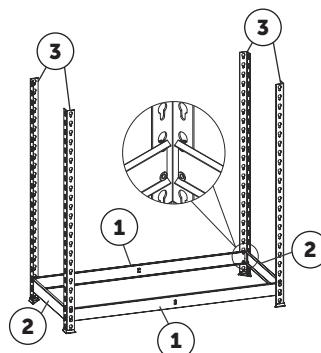
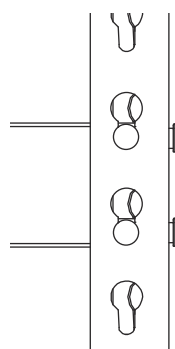
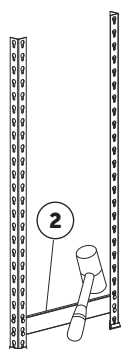

How To.

ASSEMBLY GUIDE

Boltless 5 Shelf Unit



SS-10489

Step 3

Add the brace (4). Ensure the rivets are fixed as per image. Using a flat head screwdriver, insert it into the slot and gently increase the opening width to allow for the tooth to enter. Hint: Bending the tooth inward will further secure the support in place. Install one wood board (5) on top of the assembled beams.

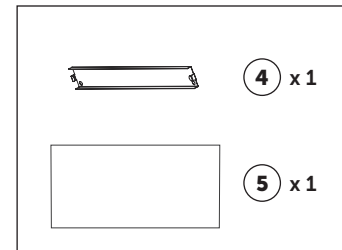
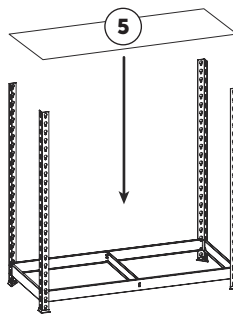
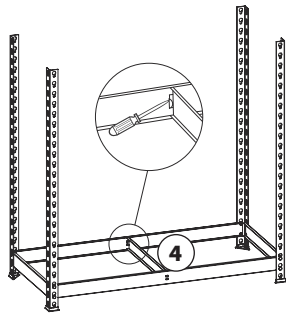

Step 4

For the second level, repeat steps 2 and 3 at desired height. Attach the post coupler (7) by sliding into the top of the post (3) and locking into key hole position. Use a rubber mallet (not included) to secure the connections.

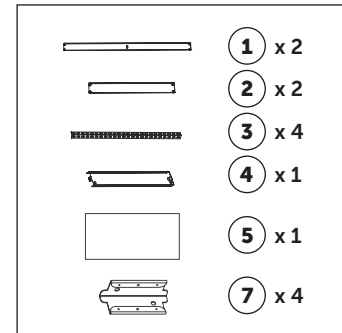
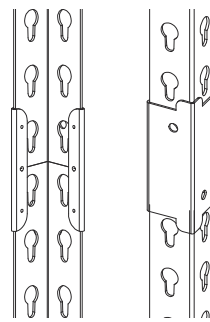
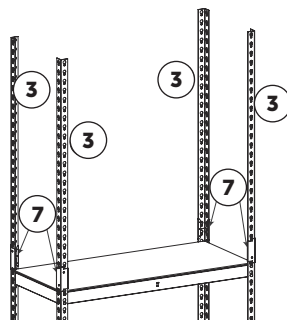
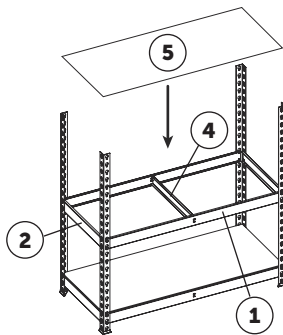

Step 5

Continue working your way upward to install the remaining shelf beams at the desired heights, placing a wood board (5) onto the assembled beams when completed. Add post cap (6) onto the tops of the post (3).

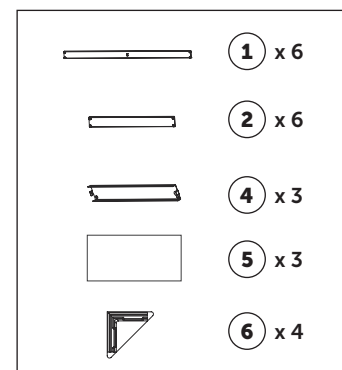
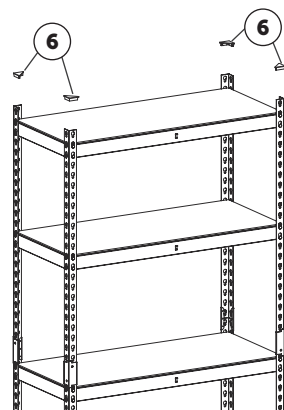

How To.

ASSEMBLY GUIDE

Boltless 5 Shelf Unit



SS-10489

Step 6

Install the anti-tip kit (part 8) to keep the rack maximum stable.

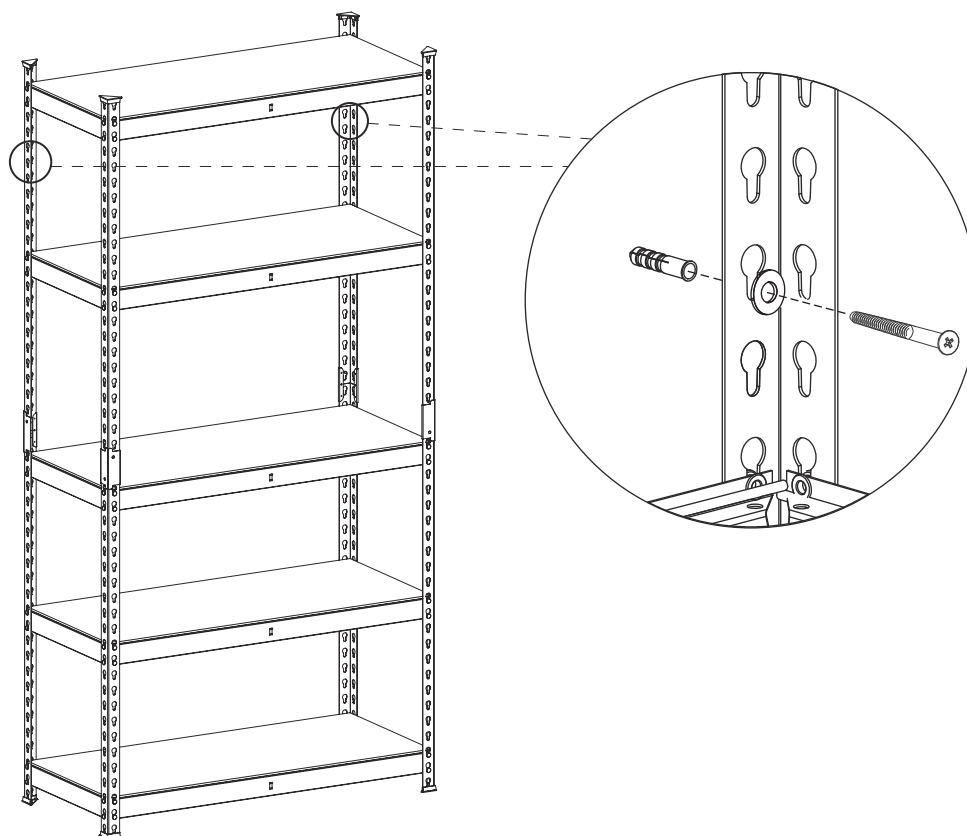
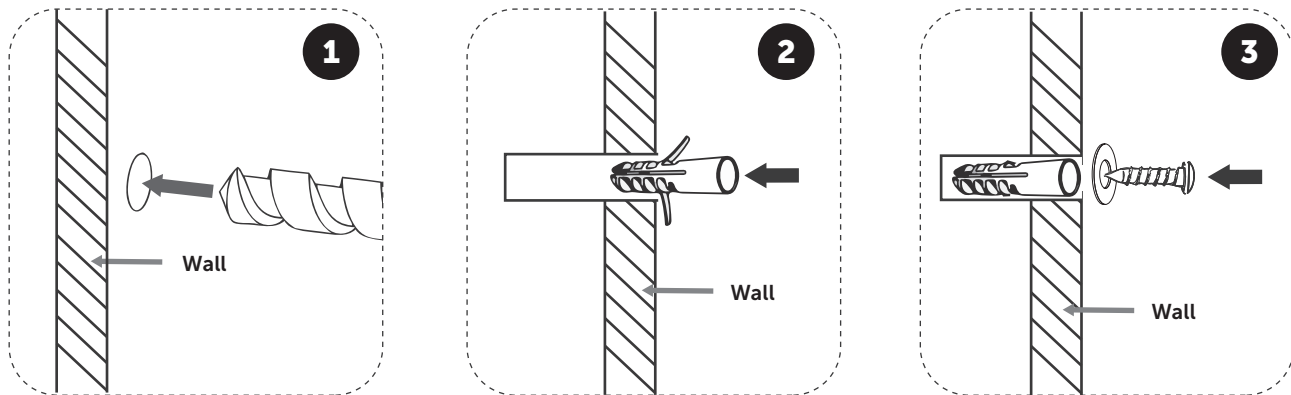

WARNING: Make sure all rivets are fully seated into the post slots. This product should be permanently anchored to a wall or other suitable surface to avoid serious or fatal injury. Do not allow children to climb on this shelf unit - it may topple over and badly injure a child.

The maximum loaded weight for each shelf is no more than 175kgs evenly distributed.